

[Return to Table of Contents](#)

# TRITEX II® SERIES

FULLY INTEGRATED SERVO DRIVE/MOTOR/ACTUATOR

Linear or Rotary configurations

AC or DC powered models

Multiple networking options



Tritex II Linear  
AC Actuator

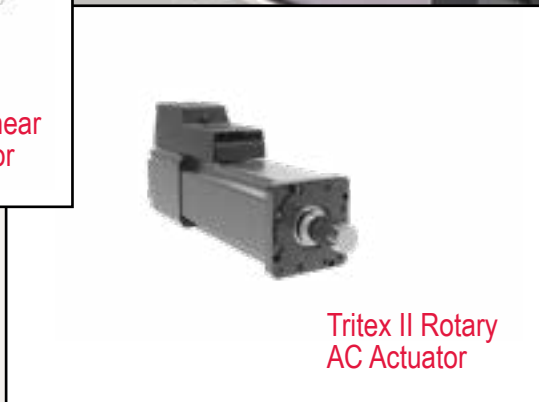

Tritex II Rotary  
AC Actuator

## Tritex® Series

### Fully Integrated Drive/Motor/Actuator

By combining the latest electronic power technology with advanced thermal management modeling technology, Exlar® has set a new benchmark for electric actuator performance versus size. Tritex II actuators now integrate an AC or DC powered servo drive, digital position controller, brushless motor and linear or rotary actuator in one elegant, compact, sealed package. Now you can distribute motion control and resolve your application challenges with one integrated device. Simply connect power, I/O, communications and go!

### Dramatically Reduce Space Requirements

Tritex II actuators are the highest power density, smallest footprint servo drive devices on the market. Finally, you can incorporate a fully electronic solution in the space of your existing hydraulic or pneumatic cylinder. You can also eliminate troublesome ball screw actuators or bulky servo gear reducers. And the space previously consumed by panel mount servo drives and motion controllers is no longer needed. Tritex II actuators may also reduce the size of your machine design while significantly improving reliability.

### Reduce Costs

Now you can eliminate the labor costs for mounting and wiring panels because the Tritex II houses the servo drive, digital positioner, and actuator in one convenient package. Cable costs are also significantly reduced by eliminating the need for expensive, high-maintenance specialty servo cables. All that is required is an economical standard AC or DC power cord, and standard communication cable for digital and analog I/O.

These actuators also eliminate the issues associated with power signals and feedback signals traveling long distances from servo drive to servo motor. With the Tritex II, the servo drive and motor are always integrated in the same housing.

### Flexible Communications

Multiple feedback types, including absolute feedback, allow you to select the system that is best-suited for your application. Digital and analog I/O, plus popular communication networks, such as Modbus TCP, Ethernet/IP, and PROFINET IO, allow the Tritex II to become an integral part of your control architecture or machine control processes.

### Improves Power, Performance, and Reliability

Tritex II actuators give you unrivaled power, performance, and reliability. No longer are you limited to trivial amounts of force or speeds so slow that many motion applications are not possible.

#### Tritex II AC Actuator

- Continuous force to 3225 lbf (14kN)
- Peak force to 5400 lbf (24kN)
- Speed to 33 in/sec (800 mm/sec)
- 1.5 kW servo amplifier
- Temperature operation range -40°C to +65°C
- AC power 100V – 240V, +/-10%

#### Tritex II DC Actuator

- Continuous force to 872 lbf (4kN)
- Peak force to 1190 lbf (5kN)
- Speed to 33 in/sec (800 mm/sec)
- 750W servo amplifier
- Temperature operation range -40°C to +65°C
- DC power 12-48 VDC nominal

Tritex II System

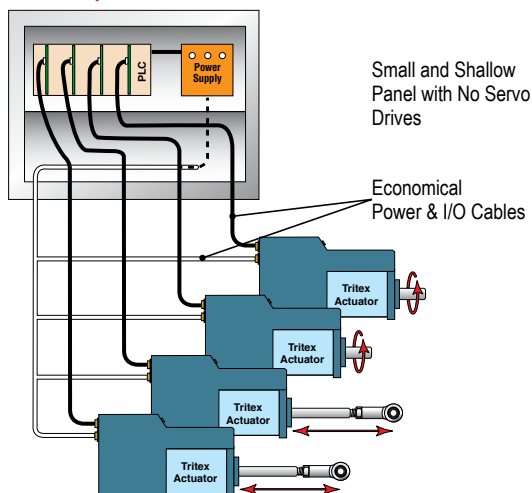

Alternative Systems

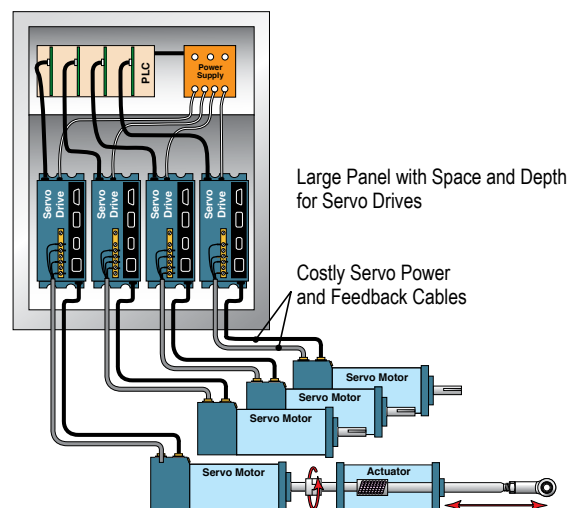

## Linear Applications

Tritex II linear actuators employ a superior inverted roller screw mechanism for converting rotary motion to highly robust and long-life linear motion. These characteristics enable the Tritex II actuator to solve applications that previously required pneumatic or hydraulic cylinders. No additional mechanisms (such as acme or ball screws) are necessary to convert the actuator's rotary power into linear motion in order to move the load.

Ideal for mobile and remote applications using DC power sources, the Tritex II DC actuators have the power needed to perform. The simple to configure, yet robust interface software allows either the AC or DC Tritex II actuators to perform nearly any motion control application. The Tritex II linear actuator can be programmed to follow an analog command signal, making it ideal for controlling valves and dampers in process control applications or adjustment mechanisms on mobile equipment.

## Longer Stroke Lengths

If your application requires a stroke length greater than the 18 inches available with Tritex II linear units, consider mounting a rotary Tritex II actuator to an Exlar universal actuator. This combination extends stroke length up to 40 inches. Please contact Exlar for more details.

## Tritex II Models

### Tritex II AC Models

- T2X high mechanical capacity actuator, 75, 90, and 115 mm
- R2M rotary motor, 75, 90, and 115 mm
- R2G rotary gearmotor, 75, 90, and 115 mm

### Tritex II DC Models

- TDX high mechanical capacity actuator, 60 and 75 mm
- RDM rotary motor, 60, 75, and 90 mm
- RDG rotary gearmotor, 60, 75, and 90 mm

### Feedback Types (All Models)

- Analog Hall w/1000 count resolution
- Incremental encoder with 8192 count resolution
- Absolute Feedback (analog hall with multi-turn, battery backup)

### Communications & I/O

The I/O count and type varies with each actuator model and option selected. Please see page 45 for Tritex II AC and page 72 for Tritex II DC models.

### Standard Communications (All Models):

- 1 RS485 port, Modbus RTU, opto-isolated for programming, controlling and monitoring

## Rotary Applications

Tritex II rotary motors and gearmotors provide high response and precise control of a rotatable shaft, similar to that found in any electric motor. The difference is that with Tritex II you can program (via your PC) the rotational speed and position of the output shaft in response to external commands. For example, the motor can be commanded to rotate at a controlled velocity and to precisely stop at a preprogrammed position. You can also program the unit to run at a preset velocity until a switch input is received or a preprogrammed torque level is produced against a load. Alternatively, the rotary Tritex II actuators can be set up to follow an analog signal—either voltage or current—representing your choice of torque, velocity, or position.

Signals for initiating the preprogram-med velocity and position commands come from optically isolated inputs or directly via network communications. Likewise, isolated output commands of the status and events enable precise coordination with your system controls or machine operator.

## Optional Internal Gear Reducer

If your application requires greater torque and less speed than the base unit provides, the Tritex II is available with an integral servo grade planetary gear reducer. Gear ratios of 4:1 to 100:1 allow the power of Tritex II to be applied over a broad range of torque requirements.



Tritex II rotary motor with connectors

Tritex II linear actuator with customer-supplied cable glands ports

## Tritex II Series Operation

The Tritex II Series actuators can operate in one of five different motion-producing modes. These modes solve an endless variety of applications in industrial automation, medical equipment, fastening and joining, blow molding, injection molding, testing, food processing, and more.

Programmed functions are stored in the Tritex II non-volatile memory. A standard RS485 serial interface allows control, programming, and monitoring of all aspects of the motor or actuator as it performs your application. Optional communications protocols are available.

## Tritex Option Boards

- Option boards offer adding functionality to the base Tritex II actuators
  - Terminal board for customer I/O
  - Isolated 4-20mA analog input and output
- Communication buses
  - EtherNet/IP
  - Modbus TCP
  - PROFINET IO

## Connectivity

- Internal terminals accessible through removable cover (select models)
- Threaded ports for cable glands (select models)
- Optional connectors
  - M23 Power - M23/M16 I/O
- M8 connector for RS485
- M12 connector for EtherNet options
- Embedded leads (select models)

## Operating Modes

1. *Move to a position (or switch)*  
The Tritex II Series actuators allow you to execute up to 16 programmed positions or distances. You may also use a limit switch or other input device as the end condition of a move. This combination of index flexibility provides a simple solution for point-to-point indexing.
2. *Move to a preset force or torque*  
The Tritex II Series allows you to terminate your move upon the achievement of a programmed torque or force. This is an ideal mode for pressing and clamping applications.
3. *Position proportional to an analog signal*  
Ideal for process control solutions, the Tritex II Series provides the functionality to position a control valve by following an analog input signal. Therefore, it delivers precise valve control — which cannot be achieved by other electric, hydraulic, or pneumatic actuators.
4. *Velocity proportional to an analog signal*  
Tritex II actuators offer you the capability to control velocity with an analog signal. This is particularly useful with Tritex II rotary motors which offer precise control of the speed of any process or operation.
5. *Force/torque proportional to analog signal*  
Perfect for pressing and torquing applications, you can control torque with an analog input while in torque mode.

## Selectable Input Functions

- Enable • Execute Move (0-15) • Dedicated Position • Jog+
- Jog- • Jog Fast • Home • Extend Switch • Retract Switch
- Home Switch • Teach Enable • Teach Move (1-16)
- Select Move • Stop • Hold • Reset Faults
- Alternate Mode (allows you to switch between 2 operating modes)

## Selectable Output Functions

- Enabled • Homed • Ready (Enabled and Homed)
- Fault • Warning • Fault or Warning Active
- Move (0-15) in Progress • Homing • Jogging
- Jogging+ • Jogging- • Motion • In Position
- At Home Position • At Move (0-15) • Position
- Stopped • Holding • In Current Limit • In Current Fold Back
- Above Rated Current • Home

## Expert User Interface

Expert, the Tritex II user interface software, provides you with a simple way to select all aspects of configuration and control required to set up and operate a Tritex II actuator. Easy-to-use tabbed pages provide access to input all of the parameters necessary to successfully configure your motion application. 'Application' files give you a convenient way to store and redistribute configurations amongst multiple computers, and 'Drive' files allow the same configuration to be distributed to multiple Tritex II actuators. Motion setup, homing, teach mode, tuning parameters, jogging, I/O configurations, and local control are all accomplished with ease using Expert software.

## Protocol Options

The standard communication protocol for Tritex is an RS485 connection using Modbus RTU. The Modbus protocol provides a simple and robust method to connect industrial electronic devices on the same network. The Expert software acts as a Modbus Master and the Tritex II acts as the Slave device, only responding to requests commanded through the software. The Expert software allows full access to commissioning, configuring, monitoring, and controlling the Tritex II.

In addition the following protocol options are available by selecting the communication option boards. Exlar requires initial commissioning of a Tritex II actuator to be performed with the Modbus protocol.

### Modbus TCP

Modbus TCP couples Modbus communication structure from Modbus RTU with EtherNet connectivity. The Modbus TCP option is fully supported by the Expert software and offers seamless

commissioning, configuring, monitoring and controlling the Tritex II. Communication protocol DSP 301 is supported as well as DSP 402 supporting Profile Torque, Profile Velocity, Profile Position and Homing. Setup on the system is most easily achieved with the Expert software using the RS485 port. A Modbus mapping table allows you to map all of the parameters you wish to read and modify into a register bank of up to 100 registers. This allows a PLC program to perform a single read operation and a single write operation to all the parameters.

### EtherNet/IP

EtherNet/IP allows you to change, monitor, and control the Tritex II through implicit or explicit messaging initiated from your Rockwell PLC. Tritex parameters are set up through the Expert software using a Tritex II parameter to EtherNet/IP parameter mapping table. Up to 100 input, and 100 output 16 bit registers can be mapped to Tritex II parameters.

### PROFINET IO

PROFINET IO allows you to change, monitor and control the Tritex II from your Siemens PLC. Tritex parameters are set up through the Expert software using a Tritex II parameter to PROFINET IO parameter mapping table. Up to 100 input and 100 output, 16 bit registers can be mapped to Tritex II parameters.

## Modbus Mapping Screen

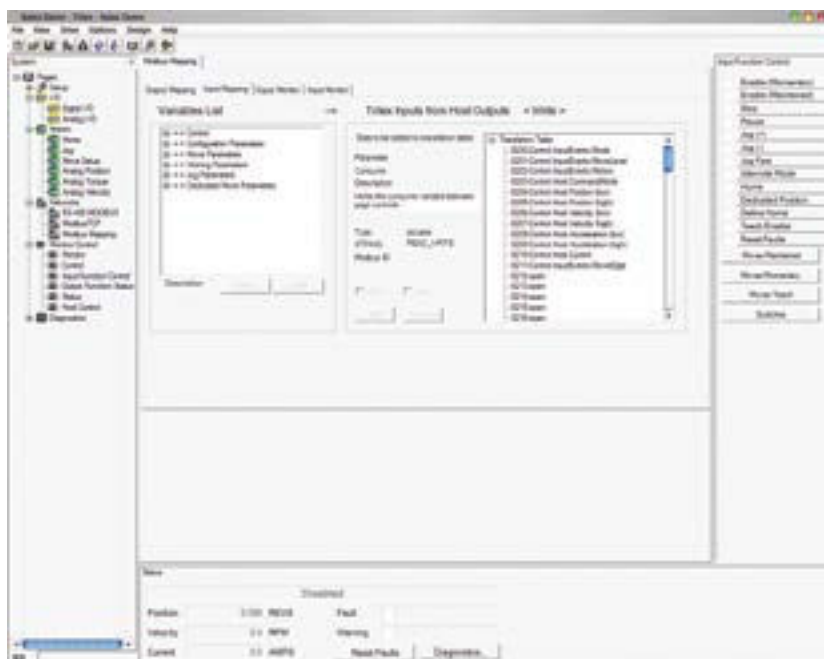

## Motion Setup

Exlar configuration provides several templates for various applications. These can serve as your configuration, or as a starting point for your configuration. You can also begin by selecting configuration details specific to your application. At the click of a button, you can configure a move to position, move to switch, or move to force motion. Tritex II products offer absolute and incremental motion, as well as moves ending on a condition, such as a specific force or torque.

## Control Page

The Expert control page gives you the ability to initiate all motion functions from one simple screen. This screen provides you with very easy system start-up and testing, without all the inconvenience of machine wiring.

The control page offers the capability to enable and disable the drive, and perform fast and slow jogs. This gives you the ability to verify motion, before needing any I/O wiring.

## Monitoring and Diagnostics

All input functions can be monitored and activated from the Expert monitor page, and all output functions can be monitored. Critical fault and status data is available as a separate page, or as a fixed window on the bottom of each page of the software.

## Configuring I/O

A drop down menu allows all I/O to be set up in a matter of minutes. Inputs can be configured to be maintained or momentary, depending on the application requirements. Input and output logic can be inverted with a single click.

## Scope

The Expert Software includes a four-channel digital oscilloscope feature.

You can select up to four Tritex drive parameters to be monitored simultaneously.

For high speed requirements, the data can be captured in the drive's memory at an adjustable rate, down to 100 micro seconds, and then uploaded for plotting. The plots can be saved or printed, and the captured data can be saved as a comma separated file for further analysis with Excel.

## Homing

You can home to an input, by using a proximity or limit switch, or home to a specific force or torque.

Homing to a force or torque is ideal for setting up applications that require motion referenced to a hard stop, like the closed position of a valve, or the final position of a press.

## Teach Mode

In this mode, you can jog the actuator to the desired position, and activate an input. Alternatively, you can click a button in the Expert software and the current position of the actuator becomes the defined distance or absolute position associated with a particular move command.

## Scope

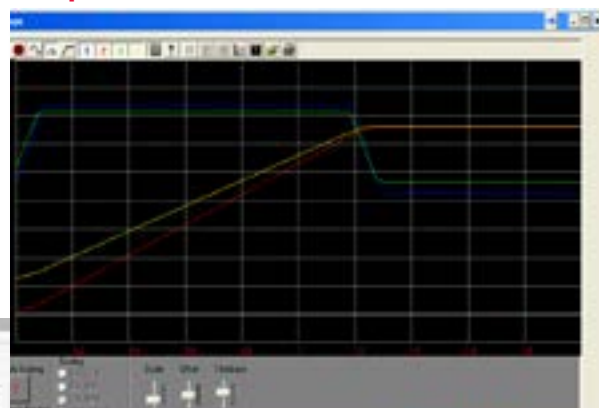

## EtherNet IP Mapping Screen

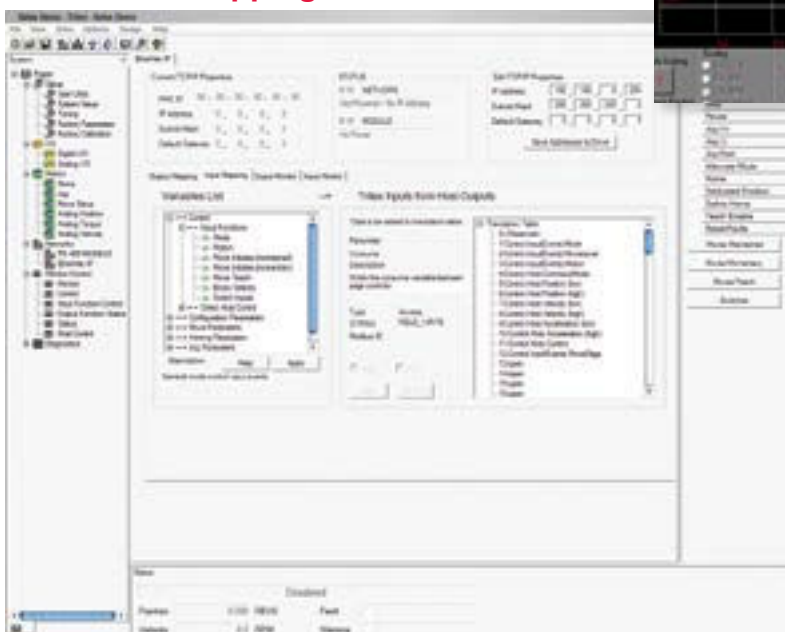

## Process Control Functionality

Precise valve and damper control are perfect applications for Tritex II actuators. They outperform other electric, hydraulic and pneumatic actuators by providing small hysteresis and dead band, quick response to small signal changes, and stable dynamic responses. Fully programmable to follow an analog or digital signal representing either position or force, the Tritex II linear actuator is well suited for control valve applications with thrust requirements up to 3225 lbf or rotary torque applications up to 95 lbf-in continuous.

The Tritex II Rotary actuators are also ideal for directly operating quarter-turn valves. Gear ratios of 4:1 to 100:1 allow the power of Tritex II to be applied to a broad range of applications, providing high turndown without loss of accuracy.

Additionally, Tritex II actuators can be mounted on any valve from any manufacturer giving you maximum flexibility.

## Valve Software

The valve software is simple to use and features a teach mode for foolproof stroke configuration. A programmable valve cut off position enables a firm valve seat on either new valves or retrofitted valves. Several diagnostics and auxiliary I/O options are also available.

## Class I, Division 2 Rating

Exlar Tritex II actuators are available for applications requiring CSA Class I Division 2 certification. Ordering a standard I/O interconnect with or without 4-20 mA Analog I/O, and the N option for the NPT port will provide you with a Class I Division 2 rated product.

## Benefits for Process Control Applications

### Extreme Accuracy

The Exlar actuators stroke the valve based on position, not air or oil pressure. Accuracy and repeatability are better than 0.1%.

### 100% Duty Cycle

A roller screw provides a unique way of converting rotary motor motion to a linear force, and offers full modulation capability. Life is measured in hundreds of million strokes vs. thousands like typical electric actuators.

### Built in Positioner

Tritex II actuators include a built in positioner with a 4-20 mA or digital signal to tell you the exact stroke position. An analog output is also available.

### Flexibility

These actuators include digital I/O and analog control. This provides the user with options for additional control such as emergency stop, +/- jog, or various diagnostic conditions.

### Low Power Consumption

The Tritex II actuator only uses the current needed for a given force. This extreme efficiency makes it suitable for use with solar panels and batteries.

### Fast Response and Stroke Speeds

Most other electric actuators are known for being slow—a major disadvantage. Tritex II response rate is measured in milliseconds. Stroke speeds can be up to 33 in/sec.

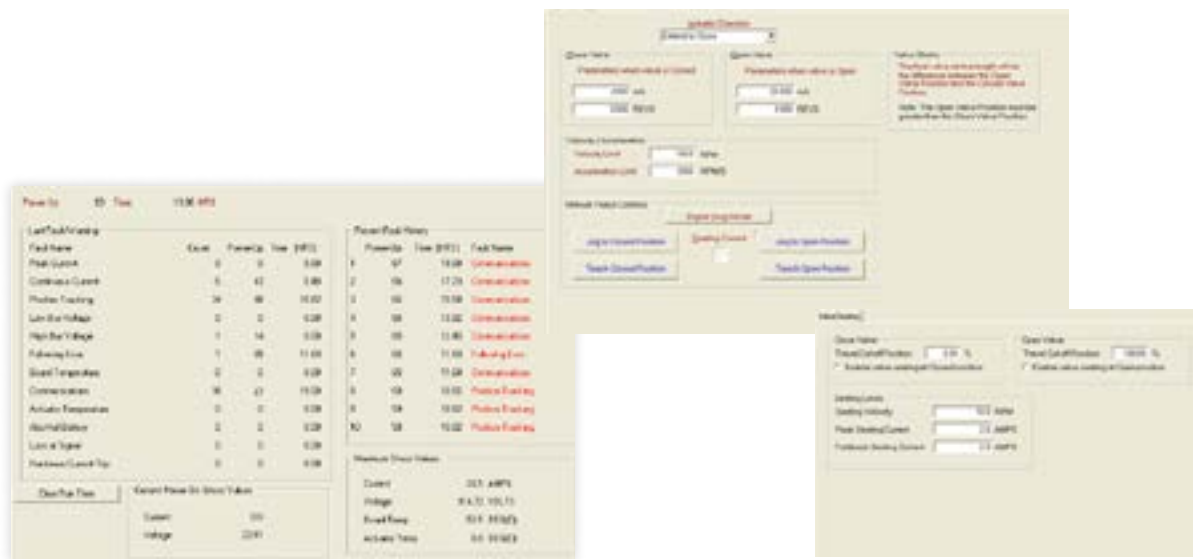

## Hydraulic Replacement

Tritex actuators have the same capabilities as a hydraulic equivalent, but without the cost or maintenance issues. High force, fast speeds and precise movements make it a superior substitute for hydraulic applications.

## Absolute Feedback

The absolute feedback option gives the actuator memory after teaching the valve limits. So upon power loss, the battery backup will maintain the valve limits.

## Diagnostics

All inputs and outputs can be monitored including position, temperature, current, and many more. An oscilloscope feature allows you to select up to four parameters to be monitored simultaneously. The data can be captured in the drive's memory at an adjustable rate, down to 100 micro sec, and then uploaded for plotting.

## Tritex II Agency Approval

If your application requires CSA Class I, Division 2 Certification, please order the "N" connection option for the NPT port. This, in combination with one of the following I/O option boards, will provide Class I, Division 2 Certification:

- SIO • EIN • TCN • IA4 • PIN

Shown below are additional agency approvals applied to Tritex II Actuators.

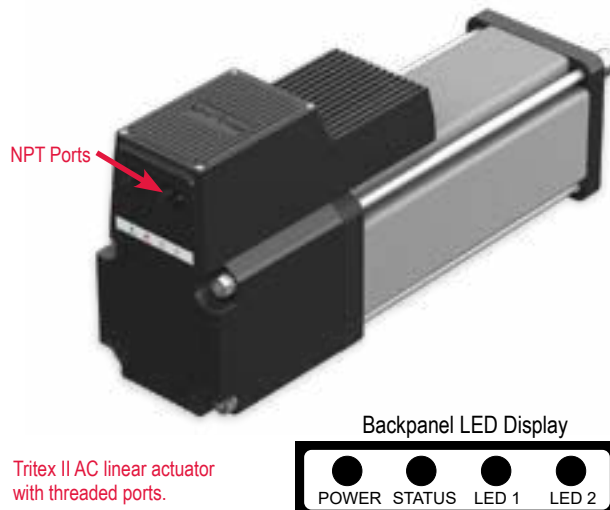

| Tritex II DC Standards/Agency Approvals |  |
|---|--|
| Agency/Standard                         | Tritex II Models/Options   |
| CE, EMC EN61800-3                       | All models   |
| CSA 139                                 | All models, when supply voltage is 24 VDC or less                        |
| CSA Class I, Div 2, Groups A, B, C, D   | 75 and 90 mm frames require NPT connection option (N/A with 60 mm frame) |
| IP Rating                               | TDX = IP65S, RDM/G = IP65  |
| Vibration Rating                        | IEC 60068-2-64 random vibration standard, 5g rms, 50 to 500 Hz.          |
| ODVA                                    | EIP  |
| PROFINET                                | PIO  |

| Tritex II AC Standards/Agency Approvals                |  |
|--|--|
| Agency/Standard  | Tritex II Models/Options   |
| CE, EMC EN61800-3, Safety EN 61800-5-1                 | All options  |
| CSA 139  | All options  |
| CSA Class I, Div 2, Groups A, B, C, D                  | Requires NPT connection option. Option Board EIN, PIN, TCN, and SIO, or IA4  |
| UL 508 C, Type 4 Enclosure T2M090/R2M090 T2M115/R2M115 | Requires NPT connection option. Option Board EIN, PIN, TCN, and SIO, or IA4  |
| IP Rating  | TDX = IP65S, T2X = IP65S<br>R2M/G & RDM/G = IP65S, R2M/G075, RDM/G075 = IP65S  |
| Vibration Rating                                       | IEC 61800-5-1 safety standard for drives. 1g peak, up to 150 Hz for <2 hrs.<br>IEC 60068-2-64 random vibration standard, 2.5 g rms, 5 to 500 Hz. |
| ODVA   | EIP  |

Up-to-date certifications for all products shown on [www.exlar.com](http://www.exlar.com).



## Tritex II AC

### No Compromising on Power, Performance or Reliability

With forces to approximately 3,225 lbf (14 kN) continuous and 5,400 lbf peak (24 kN), and speeds to 33 in/sec (800 mm/sec), the AC Tritex II linear actuators also offer a benefit that no other integrated product offers: POWER! No longer are you limited to trivial amounts of force, or speeds so slow that many motion applications are not possible. And the Tritex II with AC power electronics operates with maximum reliability over a broad range of ambient temperatures: -40°C to +65°C. The AC powered Tritex II actuators contain a 1.5 kW servo amplifier and a very capable motion controller. With standard features such as analog following for position, compound moves, move chaining, and individual force/torque control for each move, the Tritex II Series is the ideal solution for most motion applications.

#### Tritex II Models

- T2X high mechanical capacity actuator-75, 90, and 115 mm
- R2M rotary motor
- R2G rotary gearmotor

#### Power Requirements

- AC Power 100V - 240V, +/- 10%, single phase
- Built-in AC line filter
- Connections for external braking resistor

#### Feedback Types

- Analog Hall with 1000 count/motor rev resolution
- Incremental encoder with 8192 count resolution
- Absolute Feedback (analog hall with multi-turn, battery backup)

#### Connectivity

- Internal terminals accessible through removable cover
- Threaded ports for cable glands
- Optional connectors:
  - M23 Power
  - M16 I/O (M23 on 75 mm)
- M8 connector for RS485
- M12 connector for Ethernet options
- Custom connection options



Tritex II AC Linear Actuator (90 mm)

| Technical Characteristics       |  |
|---------------------------------|--|
| Frame Sizes in (mm)             | 2.9 (75), 3.5 (90), 4.5 (115)                                    |
| Screw Leads                     | 0.1 (2), 0.2 (5), 0.5 (13), 0.75 (19)                            |
| Standard Stroke Lengths in (mm) | 3 (76), 4 (102), 6 (152), 10 (254), 12 (305), 14 (356), 18 (457) |
| Force Range                     | up to 3225 lbf (14 kN)   |
| Maximum Speed                   | up to 33.3 in/s (846 mm/s)                                       |

| Operating Conditions and Usage |                                |  |
|--------------------------------|--------------------------------|--|
| <b>Accuracy:</b>               |                                |  |
| Screw Lead Error               | in/ft<br>(µm / 300 mm)         | 0.001 (25)   |
| Screw Travel Variation         | in/ft<br>(µm / 300 mm)         | 0.0012 (30)  |
| Screw Lead Backlash            | in                             | 0.004 (T2X),                                       |
| <b>Ambient Conditions:</b>     |                                |  |
| Standard Ambient Temperature   | °C                             | 0 to 65  |
| Extended Ambient Temperature** | °C                             | -40 to 65  |
| Storage Temperature            | °C                             | -40 to 85  |
| IP Rating                      |                                | T2X = IP65S<br>R2M/R2G = IP65S<br>R2M/G075 = IP66S |
| NEMA ratings                   | T2X090/R2M090<br>T2X115/R2M115 | UL Type 4<br>UL Type 4                             |
| Vibration                      |                                | 2.5 g rms, 5 to 500 hz                             |

\* Ratings for R2M075 at 40°C, operation over 40°C requires de-rating. Ratings for R2M090 and R2M115 at 25°C, operation over 25°C requires de-rating.

\*\*Consult Exlar for extended temperature operation.

## Communications & I/O

### Digital Inputs:

10 to 30 VDC Opto-isolated

### Digital Outputs:

30 VDC maximum

100 mA continuous output Isolated

### Analog Input AC:

0-10V or +/-10V

0-10V mode, 12 bit resolution

+/-10V mode, 12 bit resolution on 90/115, 13 bit resolution on

75 assignable to Position, Velocity,

Torque, or Velocity Override commands.

### Analog Output AC:

0-10V

12 bit resolution on 90/115, 11 bit resolution on 75

### IA4 option:

4-20 mA input

16 bit resolution Isolated

Assignable to Position, Velocity, or Torque command

4-20 mA output

12 bit resolution

Assignable to Position, Velocity, Current, Temperature, etc

### Standard Communications:

- 1 RS485 port, Modbus RTU, opto-isolated for programming, controlling and monitoring

The IO count and type vary with the actuator model and option module selected.

All models include isolated digital IO, and an isolated RS485 communication port when using Modbus RTU protocol.

| Tritex II AC I/O            |  |                          |                      |
|-----------------------------|--|--------------------------|----------------------|
|                             | 75/90/115 mm frame with SIO, EIP, PIO, TCP | 90/115 mm frame with IA4 | 75 mm frame with IA4 |
| Isolated digital inputs     | 8  | 8                        | 4                    |
| Isolated digital outputs    | 4  | 4                        | 3                    |
| Analog input, non isolated  | 1  | 1                        | 0                    |
| Analog output, non isolated | 1  | 1                        | 0                    |
| Isolated 4-20ma input       | 0  | 1                        | 1                    |
| Isolated 4-20ma output      | 0  | 1                        | 1                    |

## Product Features

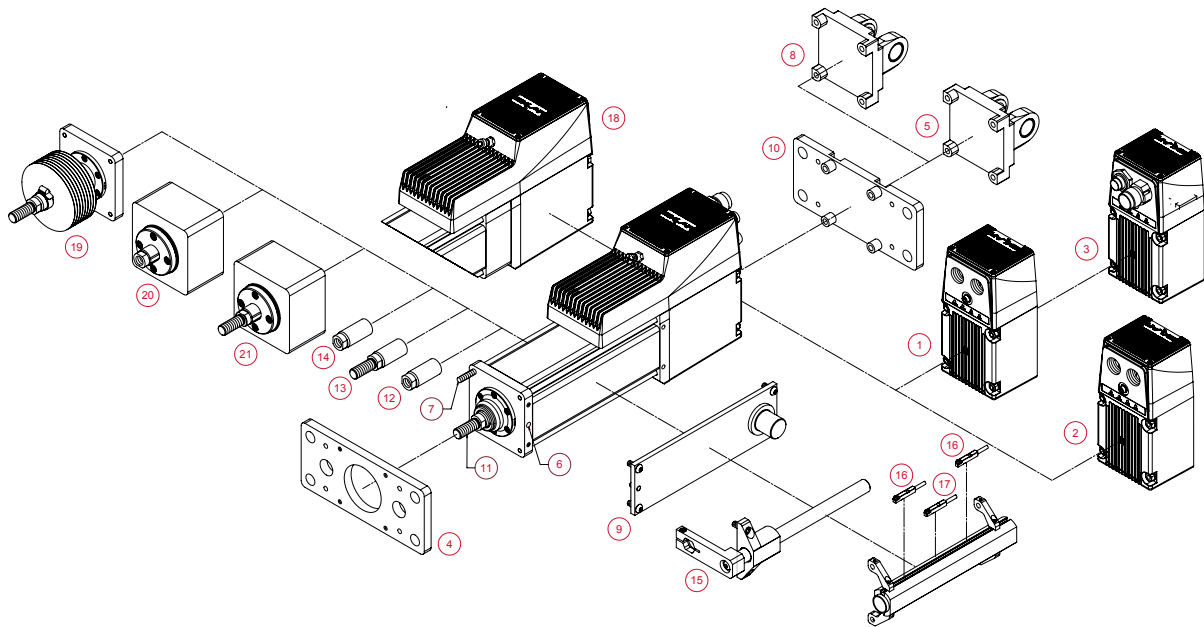
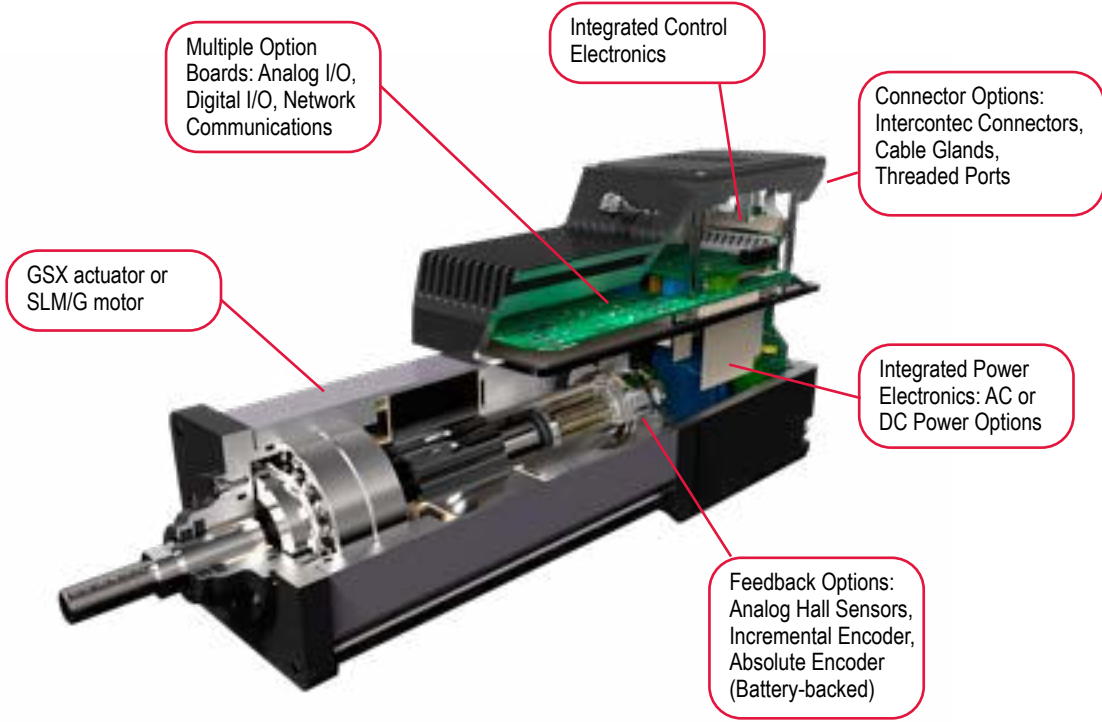

- 1 - Standard Straight Threaded Port with Internal terminals, M20 x 1.5
- 2 - NPT Threaded Port via Adapter with Internal Terminals, 1/2" NPT
- 3 - Intercontec Style - Exlar standard, M16/M23 Style Connector
- 4 - Front flange
- 5 - Rear clevis
- 6 - Double side mount and metric double side mount
- 7 - Extended tie rods and metric extended tie rods
- 8 - Metric rear clevis
- 9 - Side trunnion and metric side trunnion
- 10 - Rear flange
- 11 - Male, metric thread
- 12 - Female, metric thread
- 13 - Male, US standard thread
- 14 - Female, US standard thread
- 15 - External anti-rotate
- 16 - External limit switch - N.C., PNP
- 17 - External limit switch - N.O., PNP
- 18 - Rear brake
- 19 - Protective bellows
- 20 - Splined main rod - Female
- 21 - Splined main rod - Male

## Industries and Applications

Hydraulic cylinder replacement  
Ball screw replacement  
Pneumatic cylinder replacement

### Automotive

Clamping  
Dispensing  
Automated Assembly  
Flexible Tooling

### Food Processing

Depositing  
Slicing  
Diverters / Product Conveyance  
Sealing

### Process Control

Oil & Gas Wellhead Valve Control  
Pipeline Valve Control  
Damper Control  
Knife Valve Control  
Chemical pumps

### Entertainment / Simulation

Ride Motion Bases  
Animatronics

### Medical Equipment

Volumetric Pumps

### Plastics

Forming  
Part Eject  
Core Pull

### Material Handling

Robotic End Effectors  
Edge Guiding

Efficient food processing and packaging operations demand robust technologies that are powerful, durable, precise, and safe for food. Exlar products are ideal for these for harsh, high-capacity production environments

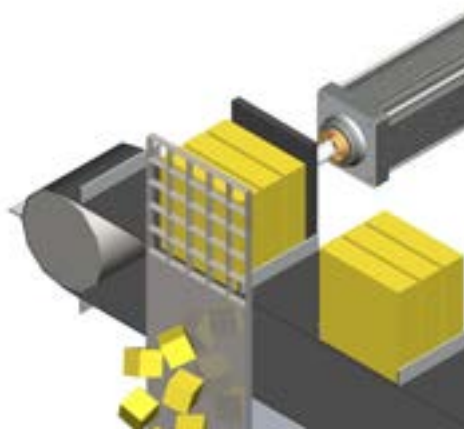

Exlar actuators can provide precision at high force loads for fluid dispensing in a medical environment.



## Mechanical Specifications

### T2X075

|  |   | Stator  | 1 Stack                | 2 Stack                 | 3 Stack       |
|--|---|---|------------------------|-------------------------|---------------|
| Lead                                     |   | RPM @ 240 VAC   | 4000                   | 3000                    | 2000          |
| 0.1                                      | Continuous Force                                | lbf (N)   | 589 (2,620)            | 990 (4,404)             | NA            |
|  | Peak Force                                      | lbf (N)   | 1,178 (5,240)          | 1,980 (8,808)***        | NA            |
|  | Max Speed                                       | in/sec (mm/sec)   | 6.67 (169)             | 5.00 (127)              | NA            |
|  | T2X - C <sub>a</sub> (Dynamic Load Rating)      | lbf (N)   | 5516 (24536)           |                         | NA            |
| 0.2                                      | Continuous Force                                | lbf (N)   | 334 (1,486)            | 561 (2,496)             | 748 (3,327)   |
|  | Peak Force                                      | lbf (N)   | 668 (2,971)            | 1,122 (4,991)           | 1,495 (6,650) |
|  | Max Speed                                       | in/sec (mm/sec)   | 13.33 (339)            | 10.00 (254)             | 6.67 (169)    |
|  | T2X - C <sub>a</sub> (Dynamic Load Rating)      | lbf (N)   | 5800 (25798)           |                         |               |
| 0.5                                      | Continuous Force                                | lbf (N)   | 141 (627)              | 238 (1,059)             | 317 (1,410)   |
|  | Peak Force                                      | lbf (N)   | 283 (1,259)            | 475 (2,113)             | 633 (2,816)   |
|  | Max Speed                                       | in/sec (mm/sec)   | 33.33 (847)            | 25.00 (635)             | 16.67 (423)   |
|  | T2X - C <sub>a</sub> (Dynamic Load Rating)      | lbf (N)   | 4900 (21795)           |                         |               |
| Drive Current @ Continuous Force         | Amps  | 3.1   | 3.8                    | 3.6                     |               |
| Available Stroke Lengths                 | in (mm)   | 3 (76), 6 (150), 10 (254), 12 (305), 14 (356), 18 (457)   |                        |                         |               |
| Inertia (zero stroke)                    | lb-in-s <sup>2</sup> / Kg-m <sup>2</sup>        | 0.002655 (0.000003000)  | 0.002829 (0.000003196) | 0.003003 (0.0000033963) |               |
| Inertia Adder (per inch of stroke)       | lb-in-s <sup>2</sup> /in/ Kg-m <sup>2</sup> /in | 0.0001424 (0.0000001609)  |                        |                         |               |
| Approximate Weight                       | lb (kg)   | 10.8 (4.9) for 3 inch stroke, 1 stack. Add 1.1 (0.5) per inch of stroke. Add 1.1 (0.5) per motor stack. Add .8 (0.4) for brake. |                        |                         |               |
| Operating Temperature Range <sup>1</sup> |   | -20C to 65C (-40°C available, consult Exlar)  |                        |                         |               |
| Continuous AC Input Current <sup>2</sup> | Amps  | 4.3   | 4                      | 3.6                     |               |

\* Ratings based on 40°C conditions.    \*\* Continuous input current rating is defined by UL and CSA    \*\*\* T2X peak force for 0.1 inch lead is 1980 lbf (8808 N)

### T2X090

|  |   | Stator  | 1 Stack                | 2 Stack                 | 2 Stack      |
|--|---|---|------------------------|-------------------------|--------------|
| Lead                                     |   | RPM @ 240 VAC   | 4000                   | 4000                    | 3000         |
| 0.1                                      | Continuous Force                                | lbf (N)   | 1,130 (5062)           | 1,488 (6619)            | NA           |
|  | Peak Force                                      | lbf (N)   | 2,260 (10053)          | 2,700 (12010)***        | NA           |
|  | Max Speed                                       | in/sec (mm/sec)   | 6.67 (169)             | 6.67 (169)              | NA           |
|  | T2X - C <sub>a</sub> (Dynamic Load Rating)      | lbf (N)   | 5516 (24536)           |                         | NA           |
| 0.2                                      | Continuous Force                                | lbf (N)   | 640 (2847)             | 843 (3750)              | 1,113 (4951) |
|  | Peak Force                                      | lbf (N)   | 1,281 (5698)           | 1,687 (7504)            | 2,225 (9897) |
|  | Max Speed                                       | in/sec (mm/sec)   | 13.33 (338)            | 13.33 (338)             | 10.00 (254)  |
|  | T2X - C <sub>a</sub> (Dynamic Load Rating)      | lbf (N)   | 5800 (25798)           |                         |              |
| 0.5                                      | Continuous Force                                | lbf (N)   | 271 (1205)             | 357 (1588)              | 471 (2095)   |
|  | Peak Force                                      | lbf (N)   | 542 (2410)             | 714 (3176)              | 942 (4190)   |
|  | Max Speed                                       | in/sec (mm/sec)   | 33.33 (847)            | 33.33 (847)             | 25.00 (635)  |
|  | T2X - C <sub>a</sub> (Dynamic Load Rating)      | lbf (N)   | 4900 (21795)           |                         |              |
| Drive Current @ Continuous Force         | Amps  | 5.7   | 7.5                    | 7.5                     |              |
| Available Stroke Lengths                 | in (mm)   | 3 (75), 6 (150), 10 (254), 12 (300), 18 (450)   |                        |                         |              |
| Inertia (zero stroke)                    | lb-in-s <sup>2</sup> / Kg-m <sup>2</sup>        | 0.002655 (0.000003000)  | 0.002829 (0.000003196) | 0.003003 (0.0000033963) |              |
| Inertia Adder (per inch of stroke)       | lb-in-s <sup>2</sup> /in/ Kg-m <sup>2</sup> /in | 0.0001424 (0.0000001609)  |                        |                         |              |
| Approximate Weight                       | lb (kg)   | 14 (6.35) for 3 inch stroke, 1 stack. Add 1 (0.5) per inch of stroke. Add 3 (1.4) per motor stack. Add 3 (1.4) for brake. |                        |                         |              |
| Operating Temperature Range <sup>1</sup> |   | -20 to 65° C (-40°C available, consult Exlar)   |                        |                         |              |
| Continuous AC Input Current <sup>2</sup> | Amps  | 6.3   | 6.3                    | 6.3                     |              |

\* Ratings based on 25°C conditions.    \*\* Continuous input current rating is defined by UL and CSA.    \*\*\* T2X peak force for 0.1 inch lead is 2700 lbf (12010 N)

## T2X115

|  |   | Stator  | 1 Stack              | 2 Stack              | 2 Stack        |
|--|---|---|----------------------|----------------------|----------------|
| Lead                                     |   | RPM @ 240 VAC   | 3000                 | 2000                 | 1500           |
| 0.1                                      | Continuous Force                                | lbf (N)   | 2,060 (9,163)        | 3,224 (14,341)       | NA             |
|  | Peak Force                                      | lbf (N)   | 4,120 (18,327)       | 5,400 (24,020)***    | NA             |
|  | Max Speed                                       | in/sec (mm/sec)   | 5.00 (127)           | 3.33 (84)            | NA             |
|  | T2X - C <sub>a</sub> (Dynamic Load Rating)      | lbf (N)   | 7900 (35141)         |                      | NA             |
| 0.2                                      | Continuous Force                                | lbf (N)   | 1,177 (5,235)        | 1,843 (8,198)        | 2,380 (10,586) |
|  | Peak Force                                      | lbf (N)   | 2,354 (10,471)       | 3,685 (16,392)       | 4,760 (21,174) |
|  | Max Speed                                       | in/sec (mm/sec)   | 10.00 (254)          | 6.67 (169)           | 5.00 (127)     |
|  | T2X - C <sub>a</sub> (Dynamic Load Rating)      | lbf (N)   | 8300 (36920)         |                      |                |
| 0.5                                      | Continuous Force                                | lbf (N)   | 530 (2,358)          | 829 (3,688)          | 1,071 (4,764)  |
|  | Peak Force                                      | lbf (N)   | 1,059 (4,711)        | 1,658 (7,375)        | 2,142 (9,528)  |
|  | Max Speed                                       | in/sec (mm/sec)   | 25.00 (635)          | 16.67 (423)          | 12.50 (317)    |
|  | T2X - C <sub>a</sub> (Dynamic Load Rating)      | lbf (N)   | 7030 (31271)         |                      |                |
| 0.75                                     | Continuous Force                                | lbf (N)   | 353 (1,570)          | 553 (2,460)          | 714 (3,176)    |
|  | Peak Force                                      | lbf (N)   | 706 (3,140)          | 1,106 (4,920)        | 1,428 (6,352)  |
|  | Max Speed                                       | in/sec (mm/sec)   | 37.5 (953)           | 25 (635)             | 17.75 (450)    |
|  | T2X - C <sub>a</sub> (Dynamic Load Rating)      | lbf (N)   | 6335 (28179)         |                      |                |
| Drive Current @ Continuous Force         | Amps  | 8.5   | 8.5                  | 8.5                  |                |
| Available Stroke Lengths                 | in (mm)   | 4 (102), 6 (150), 10 (254), 12 (300), 18 (450)  |                      |                      |                |
| Inertia (zero stroke)                    | lb-in-s <sup>2</sup> / Kg-m <sup>2</sup>        | 0.01132 (0.000012790)   | 0.01232 (0.00001392) | 0.01332 (0.00001505) |                |
| Inertia Adder (per inch of stroke)       | lb-in-s <sup>2</sup> /in/ Kg-m <sup>2</sup> /in | 0.0005640 (0.0000006372)  |                      |                      |                |
| Approximate Weight                       | lb (kg)   | 34 (15.5) for 6 inch stroke, 1 stack. Add 2 (1) per inch of stroke. Add 8 (4) per motor stack. Add 4 (2) for brake. |                      |                      |                |
| Operating Temperature Range <sup>1</sup> |   | -20 to 65° C (-40° C available, consult Exlar)  |                      |                      |                |
| Continuous AC Input Current <sup>2</sup> | Amps  | 8.3   | 8.3                  | 8.3                  |                |

\* Ratings based on 25°C conditions.

\*\* Continuous input current rating is defined by UL and CSA.

\*\*\* T2X peak force for 0.1 inch lead is 5400 lbf (24020 N)

### Rear Brake Current Draw

|        |                    |
|--------|--------------------|
| T2X075 | 0.50 Amps @ 24 VDC |
| T2X090 | 0.67 Amps @ 24 VDC |
| T2X115 | 0.75 Amps @ 24 VDC |

### DEFINITIONS:

**Continuous Force:** The linear force produced by the actuator at continuous motor torque.

**Peak Force:** The linear force produced by the actuator at peak motor torque.

**Max Speed:** The maximum rated speed produced by the actuator at rated voltage.

**C<sub>a</sub> (Dynamic Load Rating):** A design constant used in calculating the estimated travel life of the roller screw.

## Estimated Service Life

T2X075 and T2X090 Estimated L<sub>10</sub> Travel Life

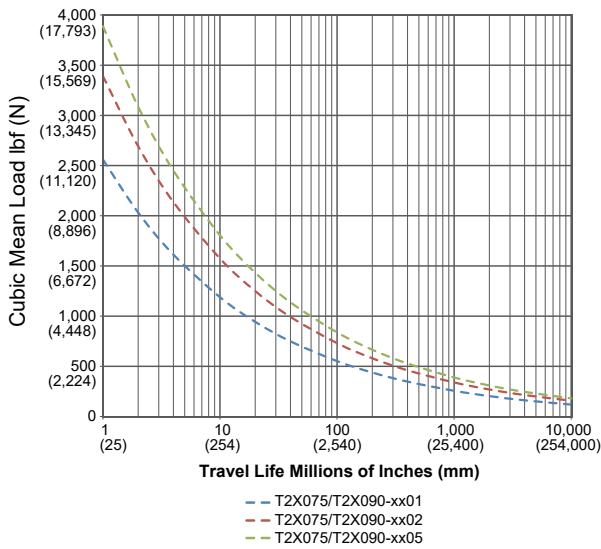

T2X115 Estimated L<sub>10</sub> Travel Life

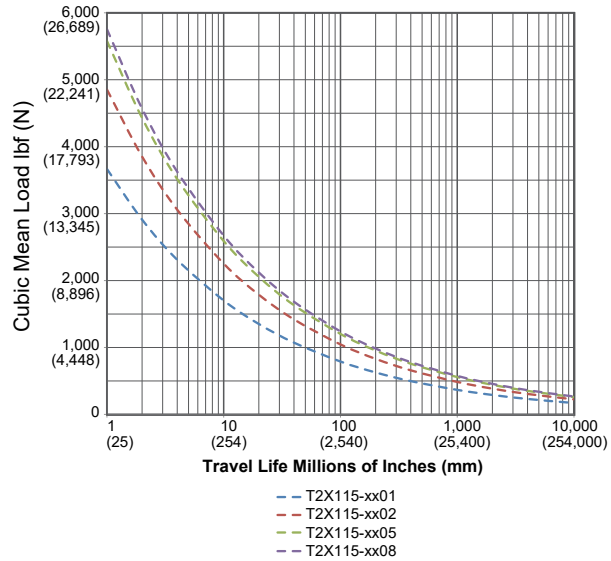

The L<sub>10</sub> expected life of a roller screw linear actuator is expressed as the linear travel distance that 90% of properly maintained roller screws are expected to meet or exceed. For higher than 90% reliability, the result should be multiplied by the following factors: 95% x 0.62; 96% x 0.53; 97% x 0.44; 98% x 0.33; 99% x 0.21. This is not a guarantee; these charts should be used for estimation purposes only.

The underlying formula that defines this value is:

Travel life in millions of inches, where:

C<sub>a</sub> = Dynamic load rating (lbf)

F<sub>cmf</sub> = Cubic mean applied load (lbf)

ℓ = Roller screw lead (inches)

$$L_{10} = \left( \frac{C_a}{F_{cmf}} \right)^3 \times \ell$$

All curves represent properly lubricated and maintained actuators.

## Speed vs. Force Curves

### Temperature Derating

The speed/torque curves are based on 25° C ambient conditions. The actuators may be operated at ambient temperatures up to 65° C. Use the curve (shown right) for continuous torque/force deratings above 25° C.

Note: T2X075 ratings are at 40° C.

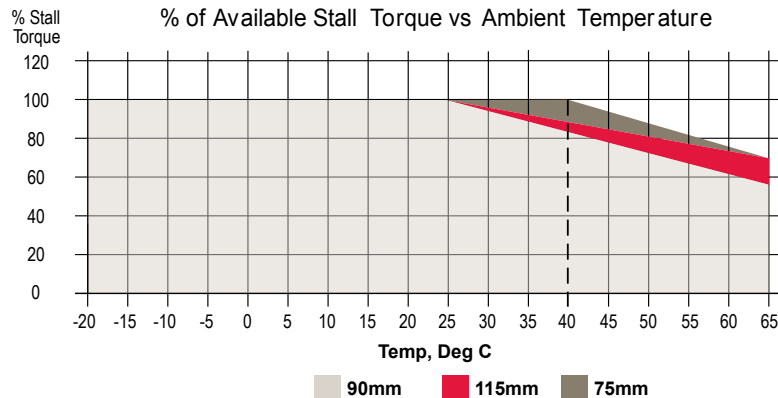

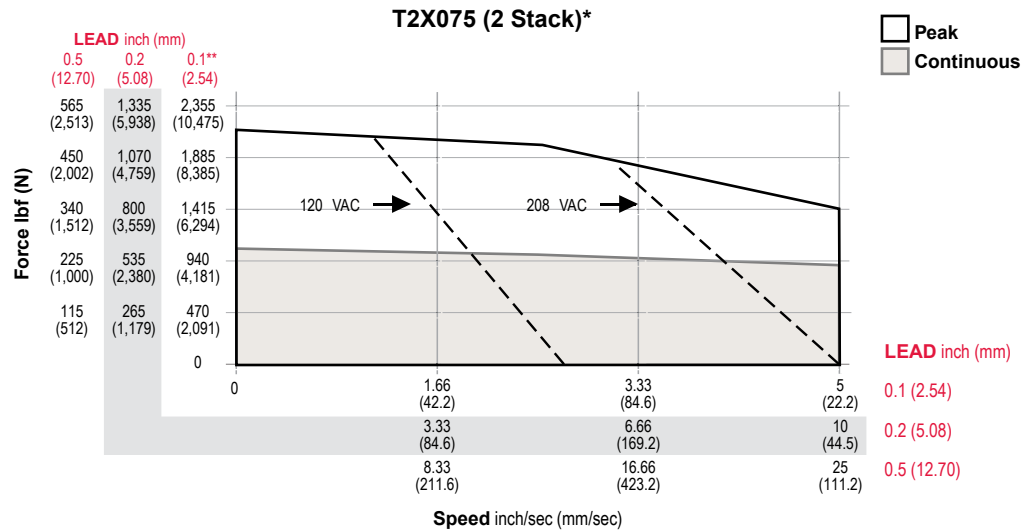
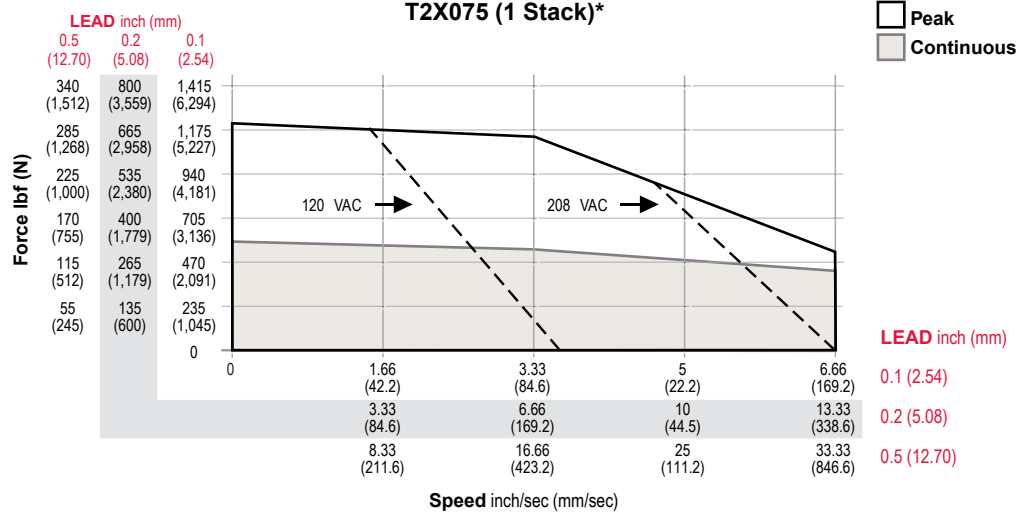

\*\*T2X peak force for 0.1 inch lead is 1980 lbf (8808 N).

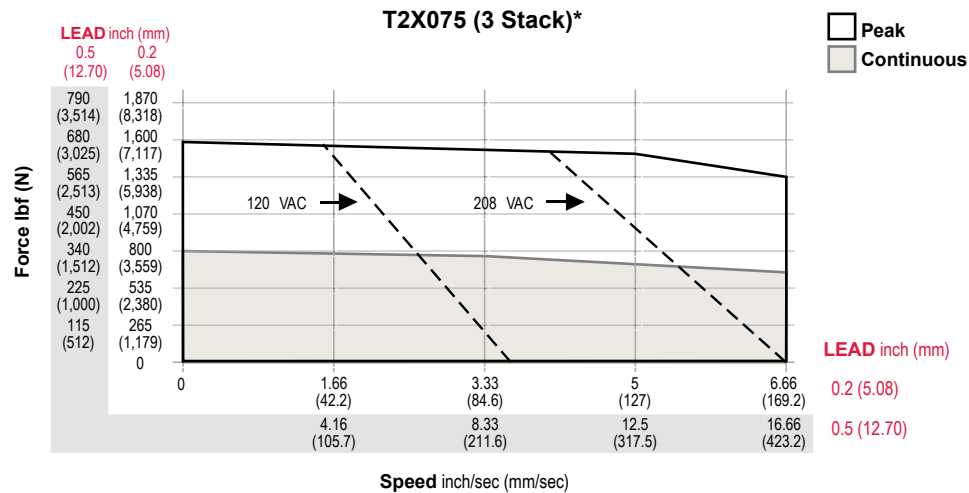

\*Test data derived using NEMA recommended aluminum heatsink 10" x 10" x 3/8" at 40°C ambient.



## T2X090 (1 Stack)\*

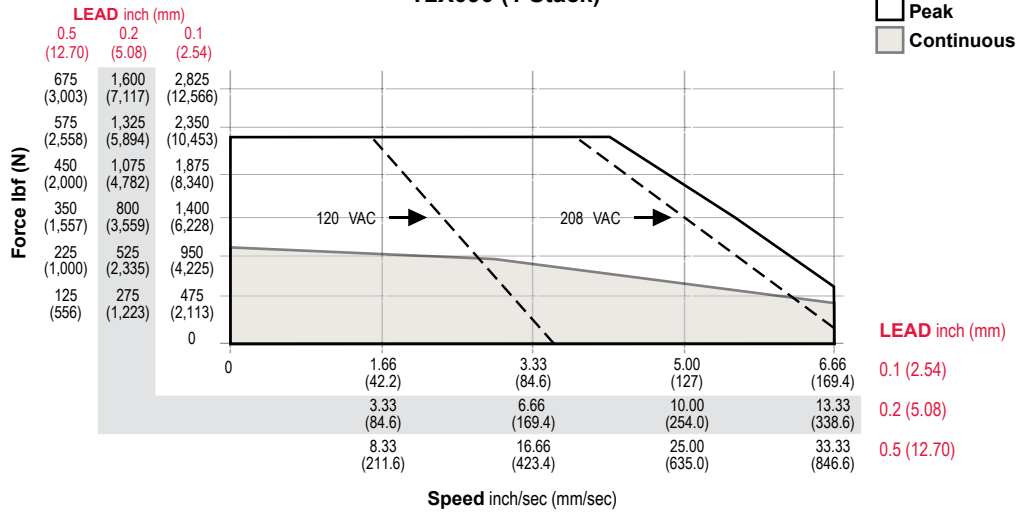

## T2X090 (2 Stack, 4000 rpm)\*

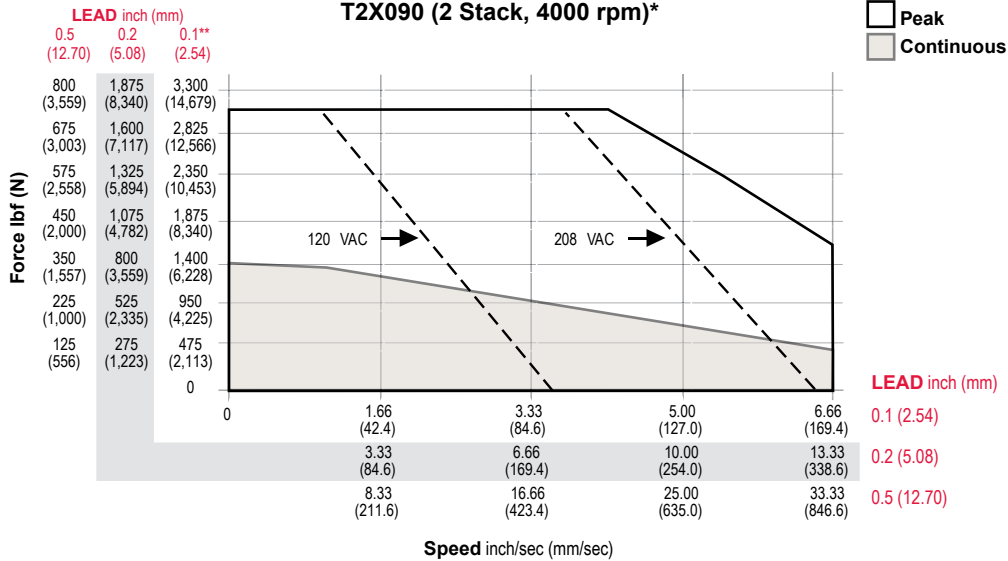

\*\*T2X peak force for 0.1 inch lead is 2700 lbf (12010 N).

## T2X090 (2 Stack, 3000 rpm)\*

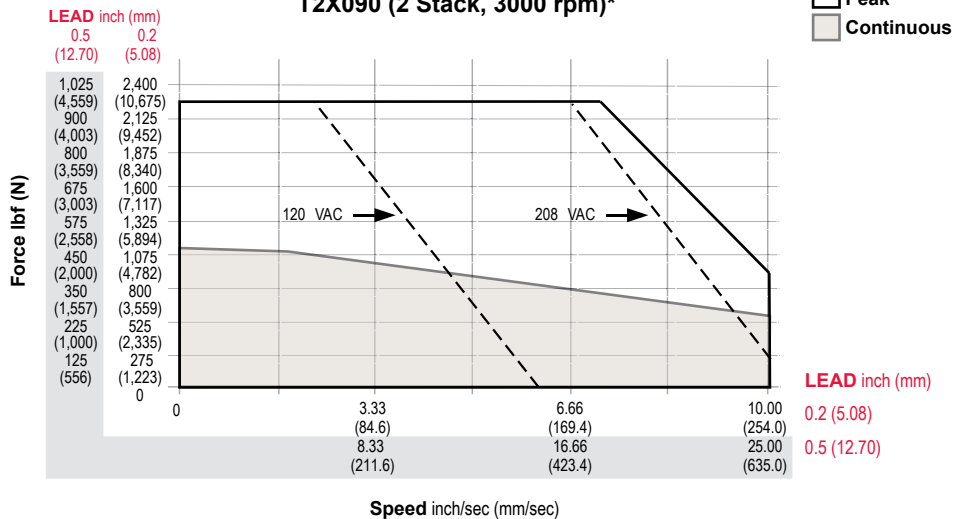

\*Test data derived using NEMA recommended aluminum heatsink 10" x 10" x 3/8" at 25°C ambient.

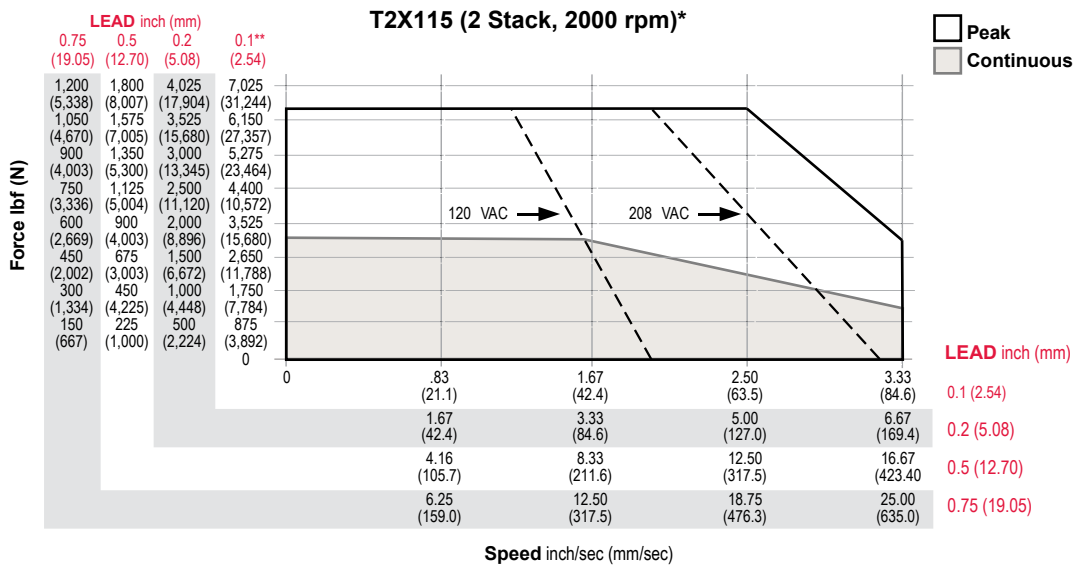
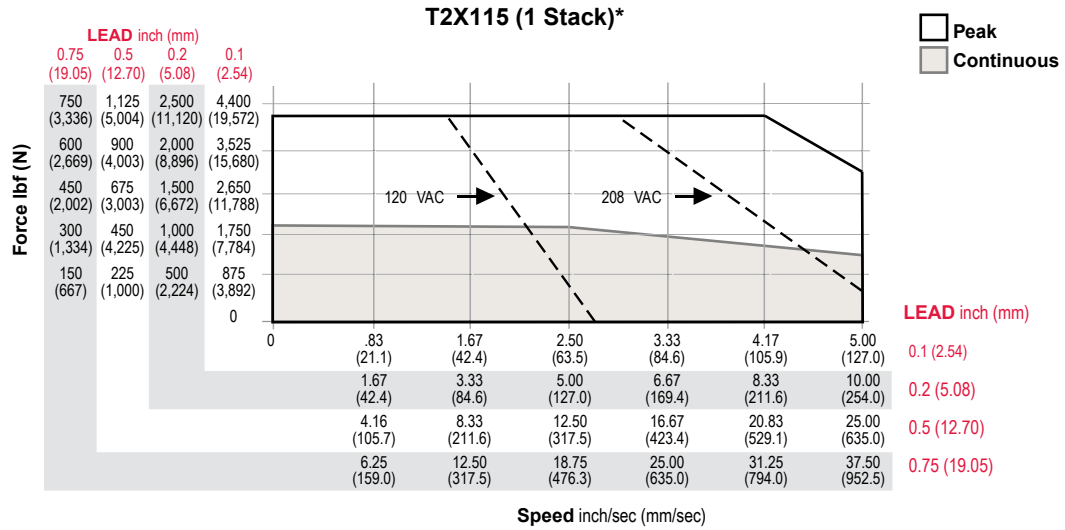

\*\*T2X peak force for 0.1 inch lead is 5400 lbf (24020 N).

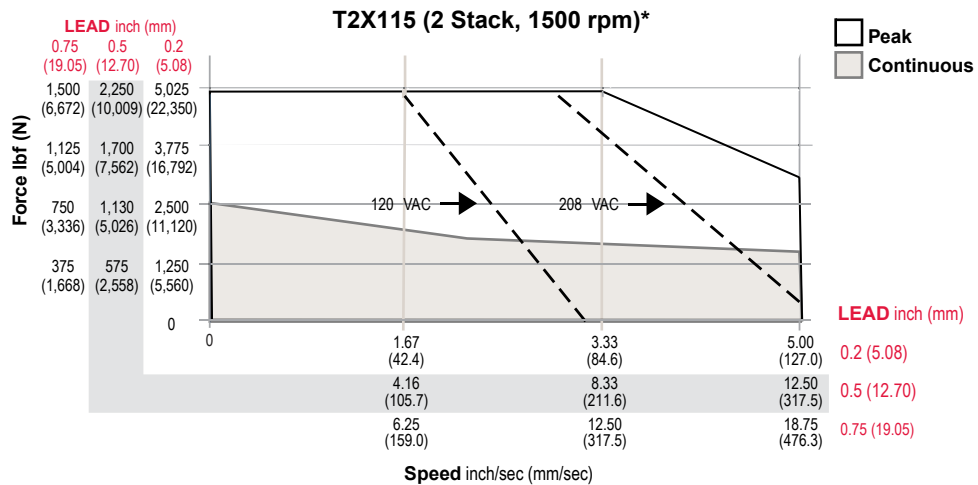

\*Test data derived using NEMA recommended aluminum heatsink 12" x 12" x 1/2" at 25°C ambient.

## Options

### **AR = External Anti-rotate Assembly**

This option provides a rod and bushing to restrict the actuator rod from rotating when the load is not held by another method. Shorter actuators have single sided anti-rotation attachments. Longer lengths require attachments on both sides for proper operation. For AR dimensions, see page 56.

### **L1, L2, L3 = Adjustable External Travel Switches**

This option allows up to 3 external switches to be included. These switches provide travel indication to the controller and are adjustable. See drawing on page 29. Must purchase external anti-rotate with this option.

### **PB = Protective Bellows**

This option provides an accordion style protective bellows to protect the main actuator rod from damage due to abrasives or other contaminants in the environment in which the actuator must survive. The standard material of this bellows is S2 Neoprene Coated Nylon,

Sewn Construction. This standard bellows is rated for environmental temperatures of -40 to 250 degrees F. Longer strokes may require the main rod of the actuator to be extended beyond standard length. Not available with extended tie rod mounting option. Please contact your local sales representative.

### **RB = Rear Electric Brake**

This option provides an internal holding brake. The brake is spring activated and electrically released.

### **SR = Splined Main Rod**

A ball spline shafting main rod with a ball spline nut that replaces the standard front seal and bushing assembly. This rod restricts rotation without the need for an external mechanism. The rod diameter will be the closest metric equivalent to our standard rod sizes. Since this option is NOT sealed, it is not suitable for environments in which contaminants may enter the actuator.

Note: Adding this option affects the overall length and mounting dimensions.

## Dimensions

### T2X075 Double Side Mount or Extended Tie Rod Mount

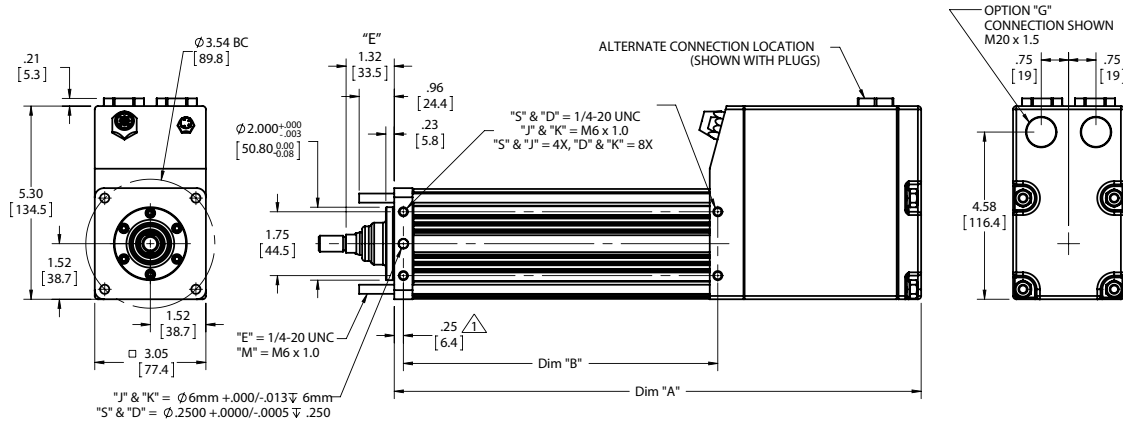

### T2X075 Side Trunnion Mount or Rear Clevis Mount

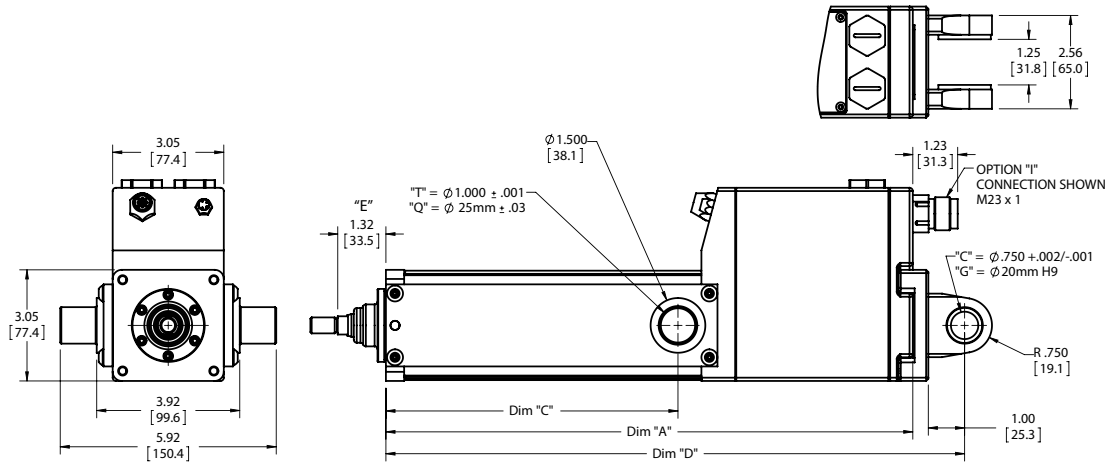

### T2X075 Front, Rear, or Front and Rear Flange Mount

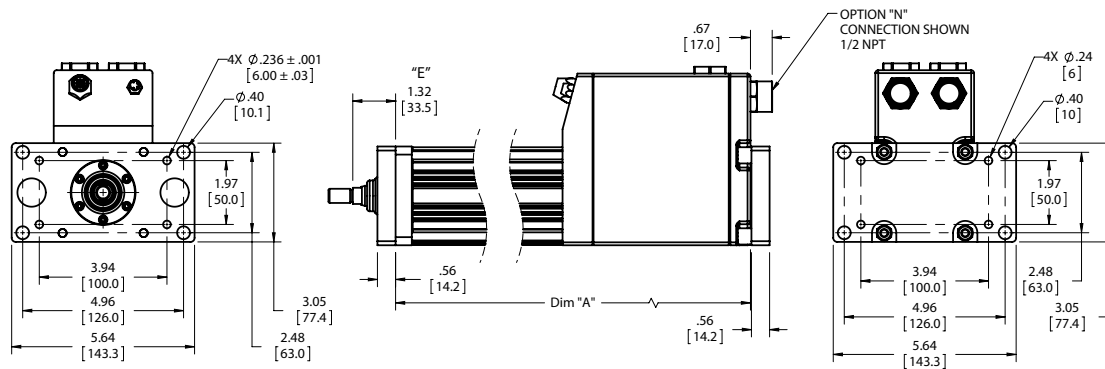

| DIM | 3 in (75 mm) stroke in (mm) | 6 in (150 mm) stroke in (mm) | 10 in (250 mm) stroke in (mm) | 12 in (300 mm) stroke in (mm) | 14 in (350 mm) stroke in (mm) | 18 in (450 mm) stroke in (mm) |
|-----|-----------------------------|------------------------------|-------------------------------|-------------------------------|-------------------------------|-------------------------------|
| A   | 11.98 (304.3)               | 14.45 (367.0)                | 18.95 (481.3)                 | 20.95 (532.1)                 | 22.95 (582.9)                 | 26.95 (684.5)                 |
| B   | 6.15 (156.2)                | 8.62 (218.9)                 | 13.12 (333.2)                 | 15.12 (384.0)                 | 17.12 (434.8)                 | 21.12 (536.4)                 |
| C   | 5.38 (136.7)                | 8.00 (203.2)                 | 10.00 (254.0)                 | 12.00 (304.8)                 | 14.00 (355.6)                 | 18.00 (457.2)                 |
| D   | 13.40 (340.4)               | 15.87 (403.1)                | 20.37 (517.4)                 | 22.37 (568.2)                 | 24.37 (619.0)                 | 28.37 (720.6)                 |

\* Add 1.61 inches to dimensions "A", "B" and "D" if ordering a brake. Add 1.2 inches to dimensions "A", "C" and "D" and dimension if ordering a splined  $\Delta$  main rod.

\*\*Add 2 in (50.8 mm) to dimension "E" if ordering protective bellows.

Pre-sale drawings and models are representative and are subject to change. Certified drawings and models are available for a fee. Consult your local Exlar representative for details.

## T2X090 Double Side Mount or Extended Tie Rod Mount

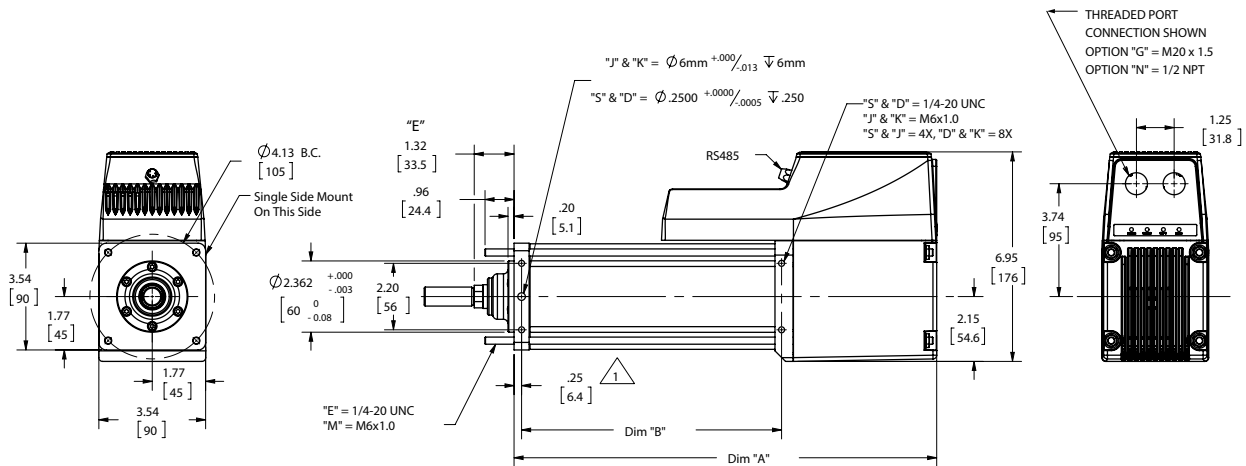

## T2X090 Side Trunnion Mount or Rear Clevis Mount

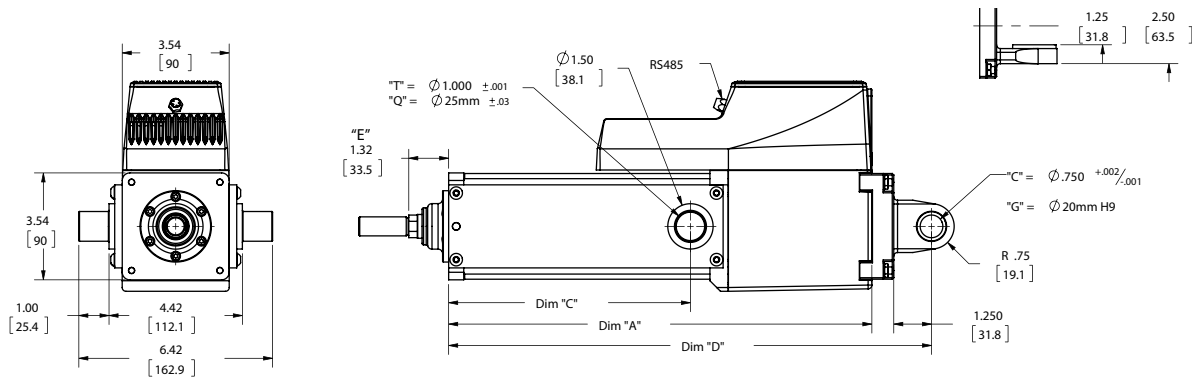

## T2X090 Front, Rear, or Front and Rear Flange Mount

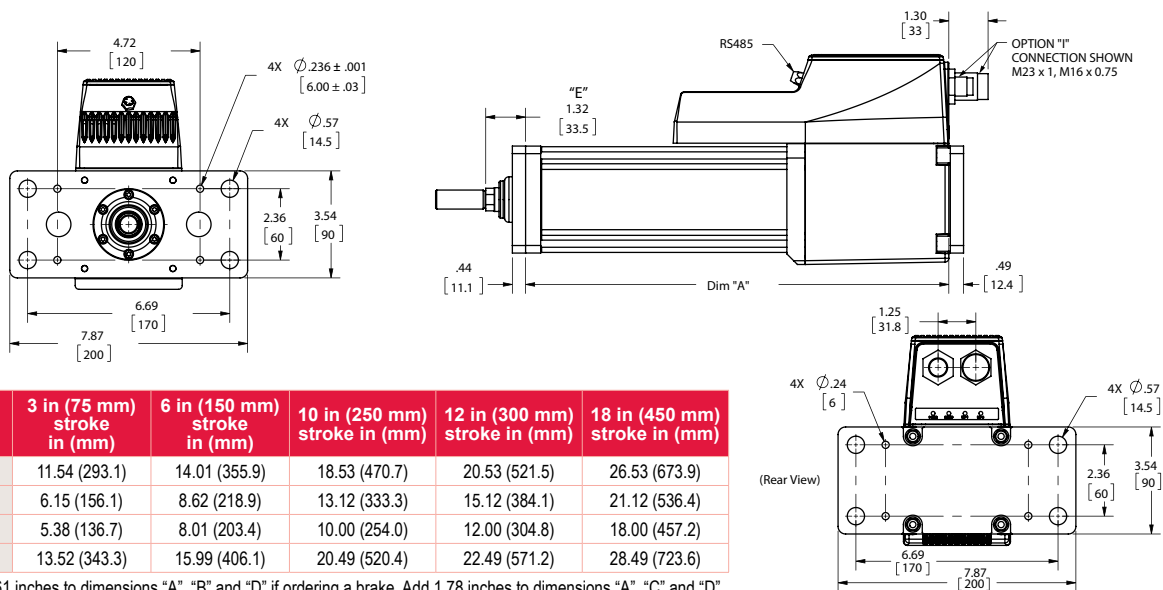

| DIM | 3 in (75 mm) stroke in (mm) | 6 in (150 mm) stroke in (mm) | 10 in (250 mm) stroke in (mm) | 12 in (300 mm) stroke in (mm) | 18 in (450 mm) stroke in (mm) |
|-----|-----------------------------|------------------------------|-------------------------------|-------------------------------|-------------------------------|
| A   | 11.54 (293.1)               | 14.01 (355.9)                | 18.53 (470.7)                 | 20.53 (521.5)                 | 26.53 (673.9)                 |
| B   | 6.15 (156.1)                | 8.62 (218.9)                 | 13.12 (333.3)                 | 15.12 (384.1)                 | 21.12 (536.4)                 |
| C   | 5.38 (136.7)                | 8.01 (203.4)                 | 10.00 (254.0)                 | 12.00 (304.8)                 | 18.00 (457.2)                 |
| D   | 13.52 (343.3)               | 15.99 (406.1)                | 20.49 (520.4)                 | 22.49 (571.2)                 | 28.49 (723.6)                 |

\* Add 1.61 inches to dimensions "A", "B" and "D" if ordering a brake. Add 1.78 inches to dimensions "A", "C" and "D" and dimension if ordering a splined  $\Delta$  main rod.

\*\*Add 2 in (50.8 mm) to dimension "E" if ordering protective bellows.

Pre-sale drawings and models are representative and are subject to change. Certified drawings and models are available for a fee. Consult your local Exlar representative for details.

## T2X115 Double Side Mount or Extended Tie Rod Mount

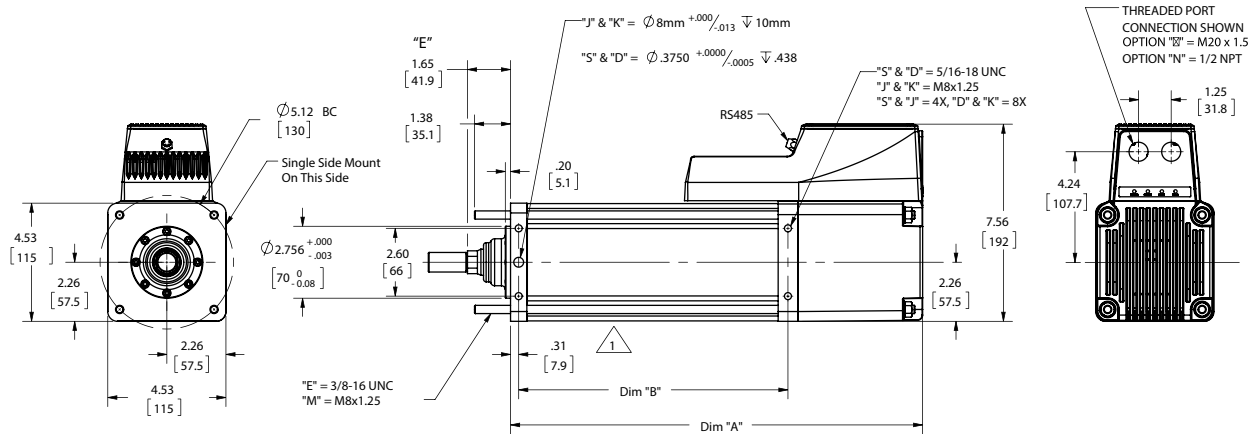

## T2X115 Side Trunnion Mount or Rear Clevis Mount

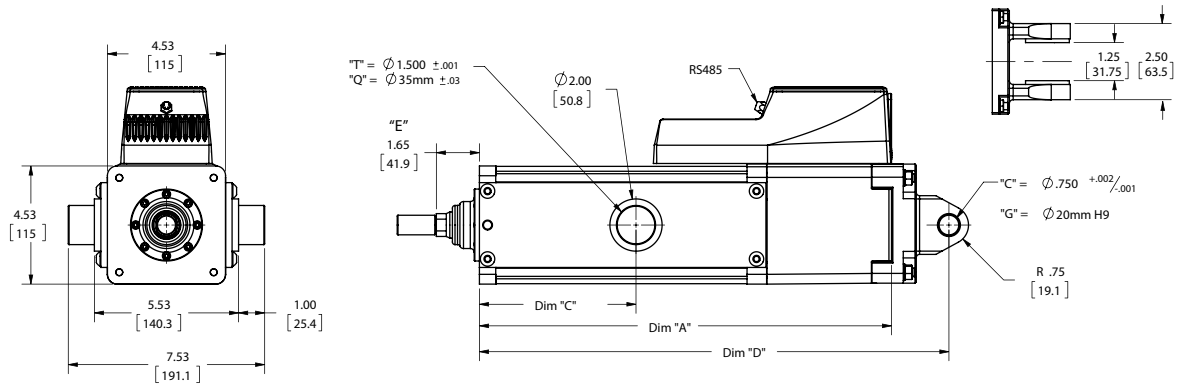

## T2X115 Front, Rear, or Front and Rear Flange Mount

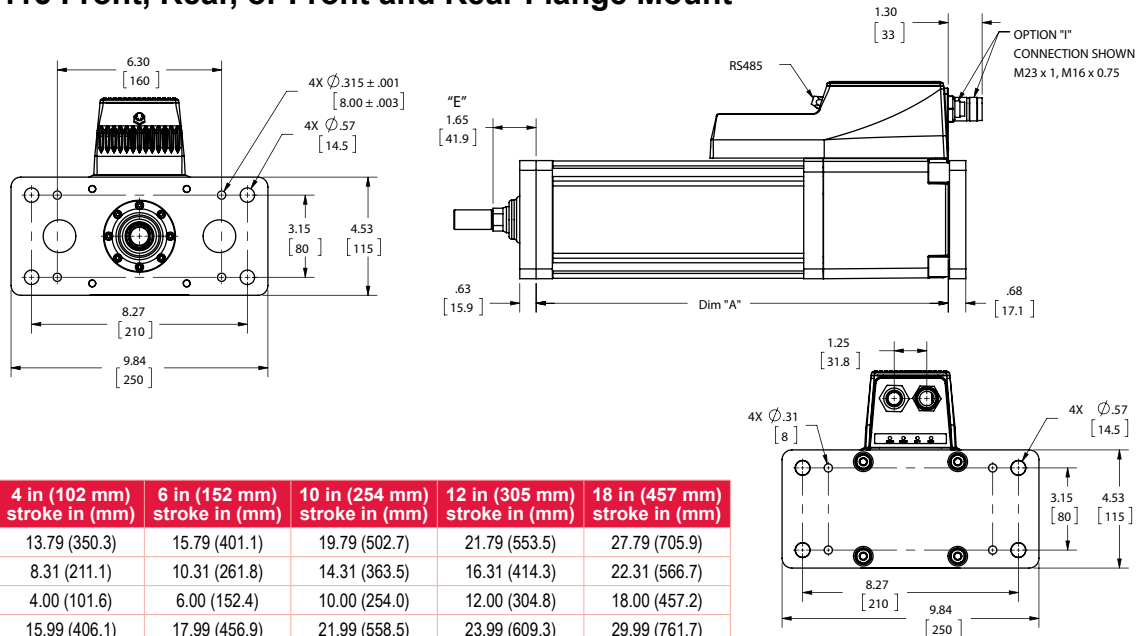

| DIM | 4 in (102 mm) stroke in (mm) | 6 in (152 mm) stroke in (mm) | 10 in (254 mm) stroke in (mm) | 12 in (305 mm) stroke in (mm) | 18 in (457 mm) stroke in (mm) |
|-----|------------------------------|------------------------------|-------------------------------|-------------------------------|-------------------------------|
| A   | 13.79 (350.3)                | 15.79 (401.1)                | 19.79 (502.7)                 | 21.79 (553.5)                 | 27.79 (705.9)                 |
| B   | 8.31 (211.1)                 | 10.31 (261.8)                | 14.31 (363.5)                 | 16.31 (414.3)                 | 22.31 (566.7)                 |
| C   | 4.00 (101.6)                 | 6.00 (152.4)                 | 10.00 (254.0)                 | 12.00 (304.8)                 | 18.00 (457.2)                 |
| D   | 15.99 (406.1)                | 17.99 (456.9)                | 21.99 (558.5)                 | 23.99 (609.3)                 | 29.99 (761.7)                 |

\* Add 2.33 inches to dimensions "A", "B" and "D" if ordering a brake. Add 1.77 inches to dimensions "A", "C" and "D" and dimension if ordering a splined  $\Delta$  main rod.

\*\*Add 2 in (50.8 mm) to dimension "E" if ordering protective bellows.

Pre-sale drawings and models are representative and are subject to change. Certified drawings and models are available for a fee. Consult your local Exlar representative for details.

## Anti-Rotate Option

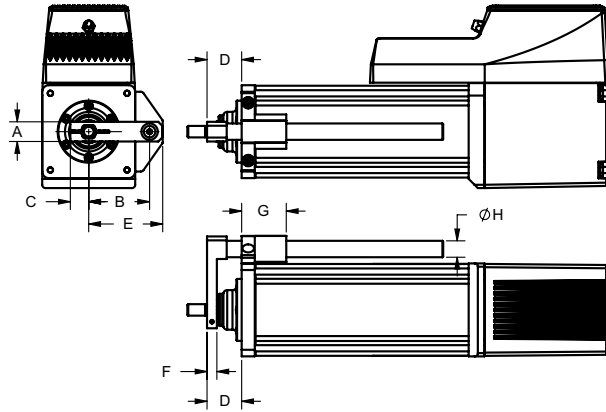

| DIM<br>in (mm) | T2X075      | T2X090      | T2X115      |
|----------------|-------------|-------------|-------------|
| A              | 0.82 (20.8) | 0.75 (19.1) | 1.13 (28.7) |
| B              | 2.20 (56.0) | 2.32 (58.9) | 3.06 (77.7) |
| C              | 0.60 (15.3) | 0.70 (17.8) | 1.00 (25.4) |
| D              | 1.32 (33.5) | 1.32 (33.5) | 1.65 (41.9) |
| E              | 2.70 (68.7) | 2.82 (71.6) | 3.63 (92.2) |
| F              | 0.39 (9.9)  | 0.38 (9.7)  | 0.50 (12.7) |
| G              | 1.70 (43.2) | 1.70 (43.2) | 1.97 (50.0) |
| ØH             | 0.63 (16.0) | 0.63 (16.0) | 0.75 (19.1) |

## Actuator Rod End Option

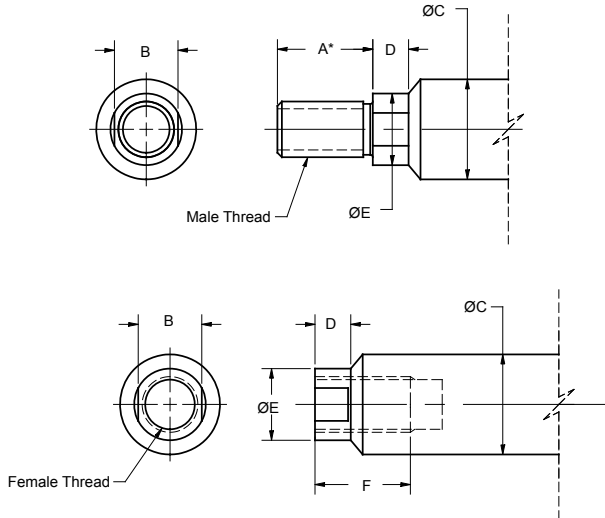

| DIM<br>in (mm)       | T2X075         | T2X090        | T2X115        |
|----------------------|----------------|---------------|---------------|
| A*                   | 0.750 (19.1)*  | 1.250 (31.8)  | 1.500 (38.1)  |
| B                    | 0.500 (12.7)   | 0.625 (17.0)  | 0.750 (19.1)  |
| ØC                   | 0.625 (15.9)   | 0.787 (20.0)  | 1.000 (25.4)  |
| D                    | 0.281 (7.1)    | 0.281 (7.1)   | 0.381 (9.7)   |
| ØE                   | 0.562 (14.3)   | 0.725 (18.4)  | 0.875 (22.2)  |
| F                    | 0.750 (19.1)   | 1.000 (25.4)  | 1.000 (25.4)  |
| Male-Inch<br>"M"     | 7/16-20 UNF-2A | 1/2-20 UNF-2A | 3/4-16 UNF-2A |
| Male-Metric<br>"A"   | M12 x 1.75 6g  | M16 x 1.5 6g  | M16 x 1.5 6g  |
| Female-Inch<br>"F"   | 7/16-20 UNF-2B | 1/2-20 UNF-2B | 5/8-18 UNF-2B |
| Female-Metric<br>"B" | M10 x 1.5 6H   | M16 x 1.5 6H  | M16 x 1.5 6H  |

\*When ordering the male M12x1.75 main rod for the T2M/X075 dimension "A" will be 1.57 in (40 mm)

## Clevis Pin

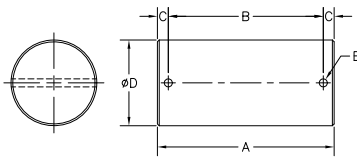

|    | T2X075/T2X090   | T2X075/T2X090                                 | T2X115  |
|----|---|---|---|
|    | <b>CP050<br/>Fits Rod Eye,<br/>Rod Clevis in (mm)</b> | <b>CP075<br/>Fits Rear Clevis<br/>in (mm)</b> | <b>CP075<br/>Fits Rod Eye, Rod<br/>Clevis, Spherical Eye,<br/>Rear Clevis in (mm)</b> |
| A  | 2.28 (57.9)   | 3.09 (78.5)                                   | 3.09 (78.5)   |
| B  | 1.94 (49.28)  | 2.72 (69.1)                                   | 2.72 (69.1)   |
| C  | 0.17 (4.32)   | 0.19 (4.82)                                   | 1.19 (4.82)   |
| ØD | 0.50 -0.001/-0.002<br>(112.7 mm +0.00/-0.05)          | 0.75 -0.001/-0.002<br>(19.1 mm +0.00/-0.05)   | 0.75 -0.001/-0.002<br>(19.1 mm +0.00/-0.05)   |
| ØE | 0.106 (2.69)  | 0.14 (3.56)                                   | 0.14 (3.56)   |





## Mechanical Specifications

### R2M/G075

| Rotary Motor Torque and Speed Ratings |  |           |           |           |
|---------------------------------------|--|-----------|-----------|-----------|
|                                       | Stator   | 1 Stack   | 2 Stack   | 3 Stack   |
|                                       | RPM at 240 VAC                                 | 4000      | 3000      | 2000      |
| Continuous Torque                     | lbf-in (Nm)                                    | 13 (1.47) | 21 (2.37) | 28 (3.16) |
| Peak Torque                           | lbf-in (Nm)                                    | 25 (2.8)  | 42 (4.75) | 56 (6.33) |
| Drive Current @ Continuous Torque     | Amps   | 3.1       | 3.8       | 3.8       |
| Operating Temperature Range*          | -20 to 65° C (-40° C available, consult Exlar) |           |           |           |
| Continuous AC Input Current**         | Amps   | 4.3       | 4         | 3.6       |

\*Ratings based on 40° C ambient conditions.

\*\*Continuous input current rating is defined by UL and CSA.

For output torque of R2G gearmotors, multiply by ratio and efficiency. Please note maximum allowable output torques shown below.

| Inertia                                 |   |                      |                      |                      |
|---|---|----------------------|----------------------|----------------------|
|   | Stator  | 1 Stack              | 2 Stack              | 3 Stack              |
| R2M Motor Armature Inertia (+/-5%)      | lb-in-sec <sup>2</sup><br>(kg-cm <sup>2</sup> ) | 0.000545<br>(0.6158) | 0.000973<br>(1.0996) | 0.001401<br>(1.5834) |
| R2G Gearmotor Armature Inertia* (+/-5%) | lb-in-sec <sup>2</sup><br>(kg-cm <sup>2</sup> ) | 0.000660<br>(0.7450) | 0.001068<br>(1.2057) | 0.001494<br>(1.6868) |

\*Add armature inertia to gearing inertia for total R2G system inertia.

| L <sub>10</sub> Radial Load and Bearing Life |               |               |              |              |              |             |
|--|---------------|---------------|--------------|--------------|--------------|-------------|
| RPM  | 50            | 100           | 250          | 500          | 1000         | 3000        |
| R2M075<br>lbf (N)                            | 278<br>(1237) | 220<br>(979)  | 162<br>(721) | 129<br>(574) | 102<br>(454) | 71<br>(316) |
| R2G075<br>lbf (N)                            | 343<br>(1526) | 272<br>(1210) | 200<br>(890) | 159<br>(707) | 126<br>(560) | 88<br>(391) |

Side load ratings shown above are for 10,000 hour bearing life at 25 mm from motor face at given rpm.

| Gearmotor Mechanical Ratings |       |   |   |                      |                      |
|------------------------------|-------|---|---|----------------------|----------------------|
| Model                        | Ratio | Maximum Allowable Output Torque-Set by User lbf-in (Nm) | Output Torque at Motor Speed for 10,000 Hour Life |                      |                      |
|                              |       |   | 1000 RPM lbf-in (Nm)                              | 2500 RPM lbf-in (Nm) | 4000 RPM lbf-in (Nm) |
| R2G075-004                   | 4:1   | 1618 (182.8)  | 384 (43.4)  | 292 (32.9)           | 254 (28.7)           |
| R2G075-005                   | 5:1   | 1446 (163.4)  | 395 (44.6)  | 300 (33.9)           | 260 (29.4)           |
| R2G075-010                   | 10:1  | 700 (79.1)  | 449 (50.7)  | 341 (38.5)           | 296 (33.9)           |

Two torque ratings for the R2G gearmotors are given in the table above. The left hand columns give the maximum (peak) allowable output torque for the indicated ratios of each size R2G gearmotor. This is not the rated output torque of the motor multiplied by the ratio of the reducer.

It is possible to select a configuration of the motor selection and gear ratio such that the rated motor torque, multiplied by the gear ratio exceeds these ratings. It is the responsibility of the user to ensure that the settings of the system do not allow these values to be exceeded.

The right hand columns give the output torque at the indicated speed which will result in 10,000 hour life (L10). The setup of the system will determine the actual output torque and speed.

| Gearing Reflected Inertia |                         |                       |
|---------------------------|-------------------------|-----------------------|
| Single Reduction          |                         |                       |
| Gear Stages               | lbf-in-sec <sup>2</sup> | (kg-cm <sup>2</sup> ) |
| 4:1                       | 0.000095                | (0.107)               |
| 5:1                       | 0.000062                | (0.069)               |
| 10:1                      | 0.000017                | (0.019)               |

| Backlash and Efficiency     |                  |                  |
|-----------------------------|------------------|------------------|
|                             | Single Reduction | Double Reduction |
| Backlash at 1% Rated Torque | 10 Arc min       | 13 Arc min       |
| Efficiency                  | 91%              | 86%              |

| Motor and Gearmotor Weights |                      |                             |                        |
|-----------------------------|----------------------|-----------------------------|------------------------|
|                             | R2M075 without Gears | R2G075 with 1 Stage Gearing | Added Weight for Brake |
| 1 Stack Stator lb (kg)      | 7.4 (3.4)            | 9.8 (4.4)                   | 1.0 (0.5)              |
| 2 Stack Stator lb (kg)      | 9.2 (4.2)            | 11.6 (5.3)                  |                        |
| 3 Stack Stator lb (kg)      | 11 (4.9)             | 13.4 (6.1)                  |                        |

## R2M/G090

| Rotary Motor Torque and Speed Ratings |  |          |          |            |
|---------------------------------------|--|----------|----------|------------|
|                                       | Stator   | 2 Stack  | 2 Stack  | 3 Stack    |
|                                       | RPM at 240 VAC                                 | 4000     | 3000     | 2000       |
| Continuous Torque                     | lbf-in (Nm)                                    | 30 (3.4) | 40 (4.5) | 52 (5.9)   |
| Peak Torque                           | lbf-in (Nm)                                    | 60 (6.8) | 80 (9.0) | 105 (11.9) |
| Drive Current @ Continuous Torque     | Amps   | 7.5      | 7.5      | 6.6        |
| Operating Temperature Range*          | -20 to 65° C (-40° C available, consult Exlar) |          |          |            |
| Continuous AC Input Current**         | Amps   | 6.3      | 6.3      | 6.3        |

\*Ratings based on 25° C ambient conditions.

\*\*Continuous input current rating is defined by UL and CSA.

For output torque of R2G gearmotors, multiply by ratio and efficiency. Please note maximum allowable output torques shown below.

| Inertia                                 |  |                |                |
|---|--|----------------|----------------|
|   | Stator                                       | 2 Stack        | 3 Stack        |
| R2M Motor Armature Inertia (+/-5%)      | lb-in-sec <sup>2</sup> (kg-cm <sup>2</sup> ) | 0.00097 (1.09) | 0.00140 (1.58) |
| R2G Gearmotor Armature Inertia* (+/-5%) | lb-in-sec <sup>2</sup> (kg-cm <sup>2</sup> ) | 0.00157 (1.77) | 0.00200 (2.26) |

\*Add armature inertia to gearing inertia for total inertia.

| L <sub>10</sub> Radial Load and Bearing Life |               |               |               |              |              |              |  |
|--|---------------|---------------|---------------|--------------|--------------|--------------|--|
| RPM  | 50            | 100           | 250           | 500          | 1000         | 3000         |  |
| R2M090<br>lbf (N)                            | 427<br>(1899) | 340<br>(1512) | 250<br>(1112) | 198<br>(881) | 158<br>(703) | 109<br>(485) |  |
| R2G090<br>lbf (N)                            | 350<br>(1557) | 278<br>(1237) | 205<br>(912)  | 163<br>(725) | 129<br>(574) | 89<br>(396)  |  |

Side load ratings shown above are for 10,000 hour bearing life at 25 mm from motor face at given rpm.

| Gearmotor Mechanical Ratings |       |   |   |                      |                      |
|------------------------------|-------|---|---|----------------------|----------------------|
| Model                        | Ratio | Maximum Allowable Output Torque-Set by User lbf-in (Nm) | Output Torque at Motor Speed for 10,000 Hour Life |                      |                      |
|                              |       |   | 1000 RPM lbf-in (Nm)                              | 2500 RPM lbf-in (Nm) | 4000 RPM lbf-in (Nm) |
| R2G090-004                   | 4:1   | 2078 (234.8)  | 698 (78.9)  | 530 (59.9)           | 460 (51.9)           |
| R2G090-005                   | 5:1   | 1798 (203.1)  | 896 (101.2)                                       | 680 (76.8)           | 591 (66.8)           |
| R2G090-010                   | 10:1  | 1126 (127.2)  | 1043 (117.8)                                      | 792 (89.4)           | 688 (77.7)           |
| R2G090-016                   | 16:1  | 2078 (234.8)  | 1057 (119.4)                                      | 803 (90.7)           | 698 (78.9)           |
| R2G090-020                   | 20:1  | 2078 (234.8)  | 1131 (127.8)                                      | 859 (97.1)           | 746 (84.3)           |
| R2G090-025                   | 25:1  | 1798 (203.1)  | 1452 (164.1)                                      | 1103 (124.6)         | 958 (108.2)          |
| R2G090-040                   | 40:1  | 2078 (234.8)  | 1392 (157.3)                                      | 1057 (119.4)         | 918 (103.7)          |
| R2G090-050                   | 50:1  | 1798 (203.1)  | 1787 (201.9)                                      | 1358 (153.4)         | 1179 (133.2)         |
| R2G090-100                   | 100:1 | 1126 (127.2)  | 1100 (124.3)                                      | 1100 (124.3)         | 1100 (124.3)         |

Two torque ratings for the R2G gearmotors are given in the table above. The left hand columns give the maximum (peak) allowable output torque for the indicated ratios of each size R2G gearmotor. This is not the rated output torque of the motor multiplied by the ratio of the reducer.

It is possible to select a configuration of the motor selection and gear ratio such that the rated motor torque, multiplied by the gear ratio exceeds these ratings. It is the responsibility of the user to ensure that the settings of the system do not allow these values to be exceeded.

The right hand columns give the output torque at the indicated speed which will result in 10,000 hour life (L10). The setup of the system will determine the actual output torque and speed.

| Gearing Reflected Inertia |                         |                       |                   |                         |                       |
|---------------------------|-------------------------|-----------------------|-------------------|-------------------------|-----------------------|
| Gear Stages               | Single Reduction        |                       | Double Reduction  |                         |                       |
|                           | lbf-in-sec <sup>2</sup> | (kg-cm <sup>2</sup> ) | Gear Stages       | lbf-in-sec <sup>2</sup> | (kg-cm <sup>2</sup> ) |
| 4:1                       | 0.000154                | (0.174)               | 16:1              | 0.000115                | (0.130)               |
| 5:1                       | 0.000100                | (0.113)               | 20:1, 25:1        | 0.0000756               | (0.0854)              |
| 10:1                      | 0.0000265               | (0.0300)              | 40:1, 50:1, 100:1 | 0.0000203               | (0.0230)              |

| Backlash and Efficiency     |                  |                  |
|-----------------------------|------------------|------------------|
|                             | Single Reduction | Double Reduction |
| Backlash at 1% Rated Torque | 10 Arc min       | 13 Arc min       |
| Efficiency                  | 91%              | 86%              |

| Motor and Gearmotor Weights |                      |                             |                             |                        |
|-----------------------------|----------------------|-----------------------------|-----------------------------|------------------------|
|                             | R2M090 without Gears | R2G090 with 1 Stage Gearing | R2G090 with 2 Stage Gearing | Added Weight for Brake |
| 2 Stack Stator lb (kg)      | 14 (6.4)             | 22 (10)                     | 25 (11.3)                   | 1.5 (0.7)              |
| 3 Stack Stator lb (kg)      | 17 (7.7)             | 25 (11.3)                   | 28 (12.7)                   |                        |

## R2M/G115

| Rotary Motor Torque and Speed Ratings     |  |           |            |            |
|---|--|-----------|------------|------------|
|   | Stator   | 1 Stack   | 2 Stack    | 2 Stack    |
|   | RPM at 240 VAC                                 | 3000      | 2000       | 1500       |
| Continuous Torque                         | lbf-in (Nm)                                    | 47 (5.3)  | 73 (8.3)   | 95 (10.7)  |
| Peak Torque                               | lbf-in (Nm)                                    | 94 (10.6) | 146 (16.5) | 190 (21.5) |
| Drive Current @ Continuous Torque         | Amps   | 8.5       | 8.5        | 8.5        |
| Operating Temperature Range <sup>†</sup>  | -20 to 65° C (-40° C available, consult Exlar) |           |            |            |
| Continuous AC Input Current <sup>**</sup> | Amps   | 8.3       | 8.3        | 8.3        |

<sup>†</sup>Ratings based on 25° C ambient conditions.

<sup>\*\*</sup>Continuous input current rating is defined by UL and CSA.

For output torque of R2G gearmotors, multiply by ratio and efficiency. Please note maximum allowable output torques shown below.

| Inertia                            |  |                |                 |
|------------------------------------|--|----------------|-----------------|
|                                    | Stator                                       | 1 Stack        | 2 Stack         |
| R2M Motor Armature Inertia (+/-5%) | lb-in-sec <sup>2</sup> (kg-cm <sup>2</sup> ) | 0.00344 (3.89) | 0.00623 (7.036) |
| R2G Gearmotor Armature Inertia*    | lb-in-sec <sup>2</sup> (kg-cm <sup>2</sup> ) | 0.00538 (6.08) | 0.00816 (9.22)  |

\*Add armature inertia to gearing inertia for total R2M system inertia.

| L <sub>10</sub> Radial Load and Bearing Life |               |               |               |               |               |              |
|--|---------------|---------------|---------------|---------------|---------------|--------------|
| RPM  | 50            | 100           | 250           | 500           | 1000          | 3000         |
| R2M115<br>lbf (N)                            | 579<br>(2576) | 460<br>(2046) | 339<br>(1508) | 269<br>(1197) | 214<br>(952)  | 148<br>(658) |
| R2G115<br>lbf (N)                            | 858<br>(3817) | 681<br>(3029) | 502<br>(2233) | 398<br>(1770) | 316<br>(1406) | 218<br>(970) |

Side load ratings shown above are for 10,000 hour bearing life at 25 mm from motor face at given rpm.

| Gearmotor Mechanical Ratings |       |   |   |                      |                      |
|------------------------------|-------|---|---|----------------------|----------------------|
| Model                        | Ratio | Maximum Allowable Output Torque-Set by User lbf-in (Nm) | Output Torque at Motor Speed for 10,000 Hour Life |                      |                      |
|                              |       |   | 1000 RPM lbf-in (Nm)                              | 2000 RPM lbf-in (Nm) | 3000 RPM lbf-in (Nm) |
| R2G115-004                   | 4:1   | 4696 (530.4)  | 1392 (157.3)                                      | 1132 (127.9)         | 1000 (112.9)         |
| R2G115-005                   | 5:1   | 4066 (459.4)  | 1455 (163.3)                                      | 1175 (132.8)         | 1040 (117.5)         |
| R2G115-010                   | 10:1  | 2545 (287.5)  | 1660 (187.6)                                      | 1350 (152.6)         | 1200 (135.6)         |
| R2G115-016                   | 16:1  | 4696 (530.4)  | 2112 (238.6)                                      | 1714 (193.0)         | 1518 (171.0)         |
| R2G115-020                   | 20:1  | 4696 (530.4)  | 2240 (253.1)                                      | 1840 (207.9)         | 1620 (183.0)         |
| R2G115-025                   | 25:1  | 4066 (459.4)  | 2350 (265.5)                                      | 1900 (214.7)         | 1675 (189.2)         |
| R2G115-040                   | 40:1  | 4696 (530.4)  | 2800 (316.4)                                      | 2240 (253.1)         | 2000 (225.9)         |
| R2G115-050                   | 50:1  | 4066 (459.4)  | 2900 (327.7)                                      | 2350 (265.5)         | 2100 (237.3)         |
| R2G115-100                   | 100:1 | 2545 (287.5)  | 2500 (282.5)                                      | 2500 (282.5)         | 2400 (271.2)         |

Two torque ratings for the R2G gearmotors are given in the table above. The left hand columns give the maximum (peak) allowable output torque for the indicated ratios of each size R2G gearmotor. This is not the rated output torque of the motor multiplied by the ratio of the reducer.

It is possible to select a configuration of the motor selection and gear ratio such that the rated motor torque, multiplied by the gear ratio exceeds these ratings. It is the responsibility of the user to ensure that the settings of the system do not allow these values to be exceeded.

The right hand columns give the output torque at the indicated speed which will result in 10,000 hour life (L10). The setup of the system will determine the actual output torque and speed.

| Gearing Reflected Inertia |                         |                       |                   |                         |                       |
|---------------------------|-------------------------|-----------------------|-------------------|-------------------------|-----------------------|
| Single Reduction          |                         |                       | Double Reduction  |                         |                       |
| Gear Stages               | lbf-in-sec <sup>2</sup> | (kg-cm <sup>2</sup> ) | Gear Stages       | lbf-in-sec <sup>2</sup> | (kg-cm <sup>2</sup> ) |
| 4:1                       | 0.000635                | (0.717)               | 16:1              | 0.000513                | (0.580)               |
| 5:1                       | 0.000428                | (0.484)               | 20:1, 25:1        | 0.000350                | (0.396)               |
| 10:1                      | 0.000111                | (0.125)               | 40:1, 50:1, 100:1 | 0.0000911               | (0.103)               |

| Backlash and Efficiency     |                  |                  |
|-----------------------------|------------------|------------------|
|                             | Single Reduction | Double Reduction |
| Backlash at 1% Rated Torque | 10 Arc min       | 13 Arc min       |
| Efficiency                  | 91%              | 86%              |

| Motor and RTG115 Gearmotor Weights |                      |                             |                             |                        |
|------------------------------------|----------------------|-----------------------------|-----------------------------|------------------------|
|                                    | R2M115 without Gears | R2G115 with 1 Stage Gearing | R2G115 with 2 Stage Gearing | Added Weight for Brake |
| 1 Stack Stator lb (kg)             | 19 (8.6)             | 34 (15.4)                   | 40 (18.1)                   | 2.7 (1.2)              |
| 2 Stack Stator lb (kg)             | 27 (12.2)            | 42 (19.1)                   | 48 (21.8)                   |                        |
| 3 Stack Stator lb (kg)             | 35 (15.9)            | 50 (22.7)                   | 56 (25.4)                   |                        |

## Speed vs. Torque Curves

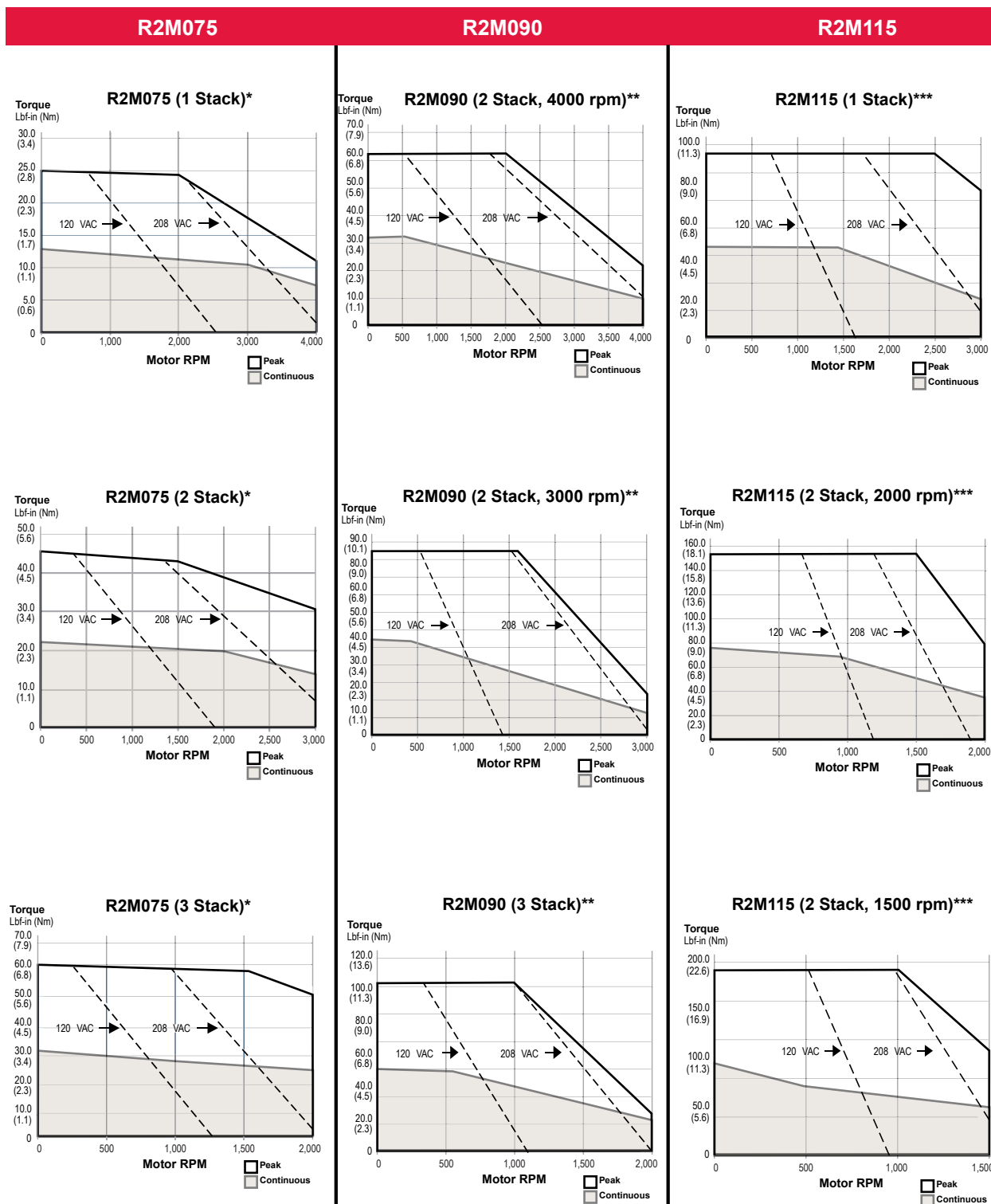

For R2G gearmotors, multiply torque by gear ratio and efficiency. Divide speed by gear ratio efficiencies; 1 Stage = 0.91, 2 Stage = 0.86

\*R2M075 test data derived using NEMA recommended aluminum heatsink 10" x 10" x 3/8" at 40°C ambient.

\*\*R2M090 test data derived using NEMA recommended aluminum heatsink 10" x 10" x 3/8" at 25°C ambient.

\*\*\*R2M115 test data derived using NEMA recommended aluminum heatsink 12" x 12" x 1/2" at 25°C ambient.

## Dimensions

### R2M/G075 Base Actuator

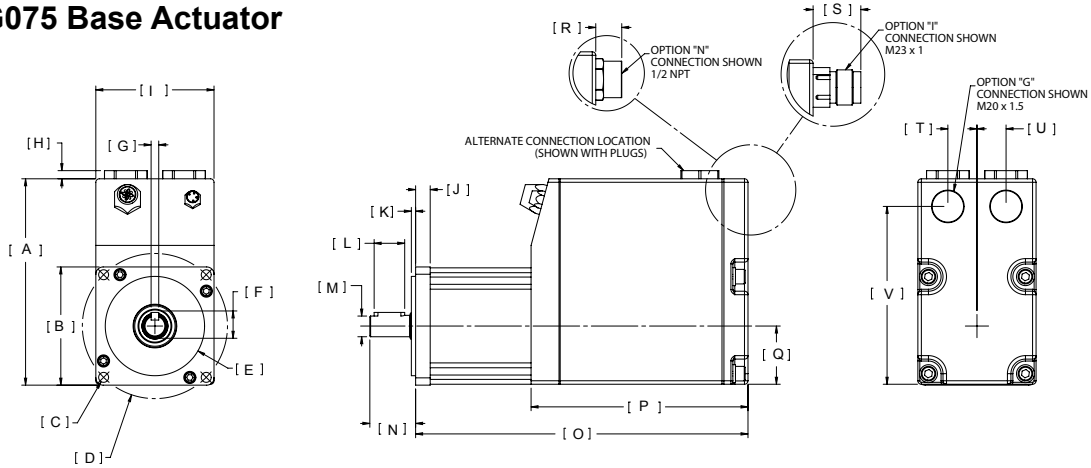

|   |    | R2M075            | R2G075            |   |    | R2M075            | R2G075            |
|---|----|-------------------|-------------------|---|----|-------------------|-------------------|
| A | in | 5.32              | 5.32              | L | in | 0.79              | 0.79              |
|   | mm | 135.1             | 135.1             |   | mm | 20.0              | 20.0              |
| B | in | □ 3.05            | □ 3.05            | M | in | ∅ 0.5512 / 0.5508 | ∅ 0.6302 / 0.6298 |
|   | mm | 77.4              | 77.4              |   | mm | 14 h6             | 16 j6             |
| C | in | 4X ∅ 0.26 ON BC   | 4X ∅ 0.26 ON BC   | N | in | 1.18              | 1.18              |
|   | mm | 6.5               | 6.5               |   | mm | 30.0              | 30.0              |
| D | in | ∅ 3.74 BC         | ∅ 3.74 BC         | O | in | See Below         | See Below         |
|   | mm | 95.0              | 95.0              |   | mm | See Below         | See Below         |
| E | in | ∅ 2.5587 / 2.5580 | ∅ 2.5587 / 2.5580 | P | in | 5.59              | 5.59              |
|   | mm | 65 g6             | 65 g6             |   | mm | 142.0             | 142.0             |
| F | in | 0.70              | 0.70              | Q | in | 1.50              | 1.50              |
|   | mm | 17.9              | 17.9              |   | mm | 38.1              | 38.1              |
| G | in | ∅ 0.1969 / 0.1957 | ∅ 0.1969 / 0.1957 | R | in | 0.67              | 0.67              |
|   | mm | 5 h9              | 5 h9              |   | mm | 17.0              | 17.0              |
| H | in | 0.21              | 0.21              | S | in | 1.23              | 1.23              |
|   | mm | 5.3               | 5.3               |   | mm | 31.3              | 31.3              |
| I | in | 3.05              | 3.05              | T | in | 0.75              | 0.75              |
|   | mm | 77.4              | 77.4              |   | mm | 19.1              | 19.1              |
| J | in | 0.38              | 0.45              | U | in | 0.75              | 0.75              |
|   | mm | 9.5               | 11.5              |   | mm | 19.1              | 19.1              |
| K | in | 0.11              | 0.11              | V | in | 4.58              | 4.58              |
|   | mm | 2.8               | 2.8               |   | mm | 116.4             | 116.4             |

### R2M075

| With Brake Option |                |                |                |
|-------------------|----------------|----------------|----------------|
| DIM               | 1 Stack Stator | 2 Stack Stator | 3 Stack Stator |
| O                 | 9.85 (250.2)   | 10.85 (275.6)  | 11.85 (301.0)  |

| Without Brake Option |                |                |                |
|----------------------|----------------|----------------|----------------|
| DIM                  | 1 Stack Stator | 2 Stack Stator | 3 Stack Stator |
| O                    | 8.57 (217.7)   | 9.57 (243.1)   | 10.57 (268.5)  |

### R2G075

| Without Brake Option |                                    |                                    |                                    |
|----------------------|------------------------------------|------------------------------------|------------------------------------|
| DIM                  | 1 Stack Stator<br>1 Stage Gearhead | 2 Stack Stator<br>1 Stage Gearhead | 3 Stack Stator<br>1 Stage Gearhead |
| O                    | 10.19 (258.8)                      | 11.19 (284.2)                      | 12.19 (309.6)                      |

| With Brake Option |                                    |                                    |                                    |
|-------------------|------------------------------------|------------------------------------|------------------------------------|
| DIM               | 1 Stack Stator<br>1 Stage Gearhead | 2 Stack Stator<br>1 Stage Gearhead | 3 Stack Stator<br>1 Stage Gearhead |
| O                 | 11.42 (290.1)                      | 12.42 (315.5)                      | 13.42 (340.9)                      |

Pre-sale drawings and models are representative and are subject to change. Certified drawings and models are available for a fee. Consult your local Exlar representative for details.

## R2M/G090 Base Actuator

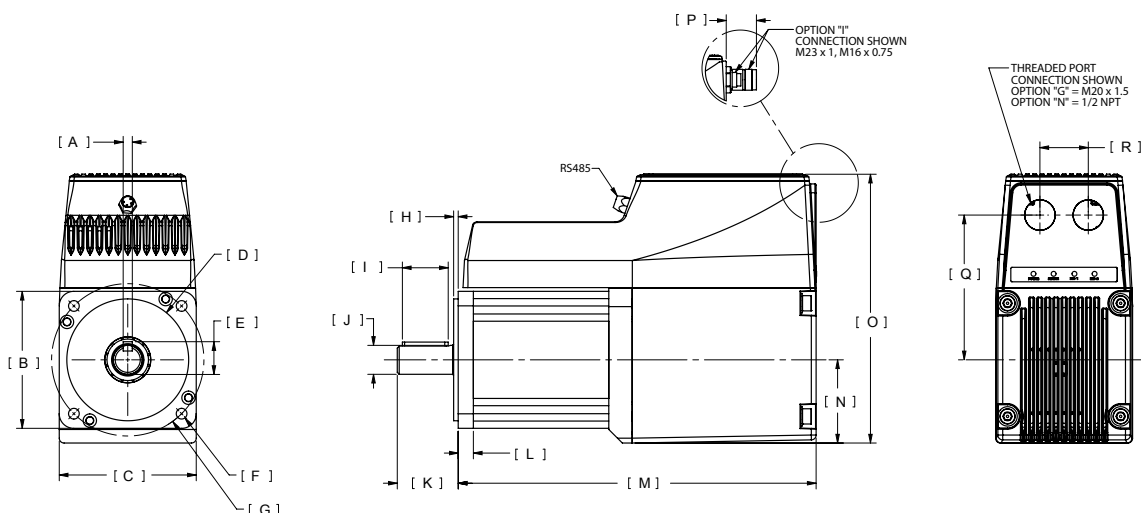

|          |    | R2M090            | R2G090            |          |    | R2M090            | R2G090            |
|----------|----|-------------------|-------------------|----------|----|-------------------|-------------------|
| <b>A</b> | in | 0.2360 / 0.2348   | 0.2362 / 0.2350   | <b>J</b> | in | Ø 0.7480 / 0.7475 | Ø 0.8665 / 0.8659 |
|          | mm | 6 h9              | 6 h9              |          | mm | 19 h6             | 22 j6             |
| <b>B</b> | in | 3.54              | 3.54              | <b>K</b> | in | 1.57              | 1.89              |
|          | mm | 90                | 90                |          | mm | 40                | 48                |
| <b>C</b> | in | 3.54              | 3.54              | <b>L</b> | in | 0.39              | 0.63              |
|          | mm | 90                | 90                |          | mm | 10                | 16                |
| <b>D</b> | in | Ø 3.1492 / 3.1485 | Ø 3.1492 / 3.1485 | <b>M</b> | in | See Below         | See Below         |
|          | mm | 80 g6             | 80 g6             |          | mm | See Below         | See Below         |
| <b>E</b> | in | 0.85              | 0.96              | <b>N</b> | in | 2.15              | 2.15              |
|          | mm | 21.5              | 24.5              |          | mm | 55                | 55                |
| <b>F</b> | in | 4X Ø 0.28 ON BC   | 4X Ø 0.257 ON BC  | <b>O</b> | in | 6.95              | 6.95              |
|          | mm | 7                 | 6.5               |          | mm | 177               | 177               |
| <b>G</b> | in | Ø 3.94 BC         | Ø 3.94 BC         | <b>P</b> | in | 1.30              | 1.30              |
|          | mm | 100               | 100               |          | mm | 33                | 33                |
| <b>H</b> | in | 0.12              | 0.118             | <b>Q</b> | in | 3.74              | 3.74              |
|          | mm | 3                 | 3                 |          | mm | 95                | 95                |
| <b>I</b> | in | 1.38              | 1.417             | <b>R</b> | in | 1.25              | 1.25              |
|          | mm | 35                | 36                |          | mm | 32                | 32                |

### R2M090

| Without Brake Option |                |                |
|----------------------|----------------|----------------|
| <b>DIM</b>           | 2 Stack Stator | 3 Stack Stator |
| M                    | 10.25 (256.3)  | 11.25 (285.8)  |

| With Brake Option |                |                |
|-------------------|----------------|----------------|
| <b>DIM</b>        | 2 Stack Stator | 3 Stack Stator |
| M                 | 11.6 (294.6)   | 12.6 (320.0)   |

### R2G090

| Without Brake Option |                                    |                                    |
|----------------------|------------------------------------|------------------------------------|
| <b>DIM</b>           | 2 Stack Stator<br>1 Stage Gearhead | 3 Stack Stator<br>1 Stage Gearhead |
| M                    | 12.36 (313.9)                      | 13.36 (339.3)                      |
| <b>DIM</b>           | 2 Stack Stator<br>2 Stage Gearhead | 3 Stack Stator<br>2 Stage Gearhead |
| M                    | 13.63 (346.2)                      | 14.63 (371.6)                      |

| With Brake Option |                                    |                                    |
|-------------------|------------------------------------|------------------------------------|
| <b>DIM</b>        | 2 Stack Stator<br>1 Stage Gearhead | 3 Stack Stator<br>1 Stage Gearhead |
| M                 | 13.67 (347.2)                      | 14.67 (372.6)                      |
| <b>DIM</b>        | 2 Stack Stator<br>2 Stage Gearhead | 3 Stack Stator<br>2 Stage Gearhead |
| M                 | 14.94 (379.5)                      | 15.94 (404.9)                      |

Pre-sale drawings and models are representative and are subject to change. Certified drawings and models are available for a fee. Consult your local Exlar representative for details.

# Tritex II AC Rotary

## R2M/G115 Base Actuator

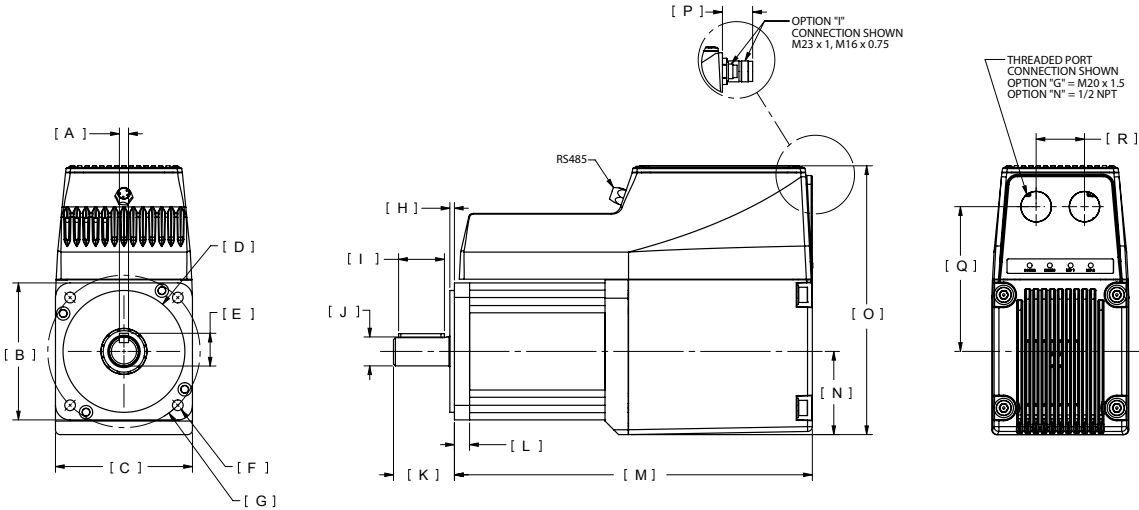

|          |    | R2M115            | R2G115            |          |    | R2M115            | R2G115            |
|----------|----|-------------------|-------------------|----------|----|-------------------|-------------------|
| <b>A</b> | in | 0.3150 / 0.3135   | 0.3937 / 0.3923   | <b>J</b> | in | Ø 0.9449 / 0.9444 | Ø 1.2603 / 1.2596 |
|          | mm | 8 h9              | 10 h9             |          | mm | 24 h6             | 32 j6             |
| <b>B</b> | in | 4.53              | 4.530             | <b>K</b> | in | 1.97              | 2.55              |
|          | mm | 115               | 115               |          | mm | 50                | 65                |
| <b>C</b> | in | 4.53              | 4.530             | <b>L</b> | in | 0.45              | 0.64              |
|          | mm | 115               | 115               |          | mm | 12                | 16                |
| <b>D</b> | in | Ø 4.3302 / 4.3294 | Ø 4.3302 / 4.3294 | <b>M</b> | in | See Below         | See Below         |
|          | mm | 110 g6            | 110 g6            |          | mm | See Below         | See Below         |
| <b>E</b> | in | 1.06              | 1.380             | <b>N</b> | in | 2.27              | 2.27              |
|          | mm | 27                | 35                |          | mm | 58                | 58                |
| <b>F</b> | in | 4 X Ø 0.34 ON BC  | 4 X Ø 0.34 ON BC  | <b>O</b> | in | 7.56              | 7.56              |
|          | mm | 8.5               | 8.5               |          | mm | 192               | 192               |
| <b>G</b> | in | Ø 5.12 BC         | Ø 5.12 BC         | <b>P</b> | in | 1.30              | 1.30              |
|          | mm | 130               | 130               |          | mm | 33                | 33                |
| <b>H</b> | in | 0.16              | 0.16              | <b>Q</b> | in | 4.23              | 4.23              |
|          | mm | 4                 | 4                 |          | mm | 108               | 108               |
| <b>I</b> | in | 1.41              | 1.58              | <b>R</b> | in | 1.25              | 1.25              |
|          | mm | 35.9              | 40                |          | mm | 32                | 32                |

### R2M115

| Without Brake Option |                |                |
|----------------------|----------------|----------------|
| <b>DIM</b>           | 1 Stack Stator | 2 Stack Stator |
| M                    | 9.87 (250.7)   | 11.87 (301.5)  |

| With Brake Option |                |                |
|-------------------|----------------|----------------|
| <b>DIM</b>        | 1 Stack Stator | 2 Stack Stator |
| M                 | 11.60 (294.6)  | 13.60 (345.4)  |

### R2G115

| Without Brake Option |                                    |                                    |
|----------------------|------------------------------------|------------------------------------|
| <b>DIM</b>           | 1 Stack Stator<br>1 Stage Gearhead | 2 Stack Stator<br>1 Stage Gearhead |
| M                    | 13.88 (352.6)                      | 15.88 (403.4)                      |
| <b>DIM</b>           | 1 Stack Stator<br>2 Stage Gearhead | 2 Stack Stator<br>2 Stage Gearhead |
| M                    | 15.49 (393.4)                      | 17.49 (444.2)                      |

| With Brake Option |                                    |                                    |
|-------------------|------------------------------------|------------------------------------|
| <b>DIM</b>        | 1 Stack Stator<br>1 Stage Gearhead | 2 Stack Stator<br>1 Stage Gearhead |
| M                 | 15.43 (391.9)                      | 17.43 (442.7)                      |
| <b>DIM</b>        | 1 Stack Stator<br>2 Stage Gearhead | 2 Stack Stator<br>2 Stage Gearhead |
| M                 | 17.04 (432.8)                      | 19.04 (483.6)                      |

Pre-sale drawings and models are representative and are subject to change. Certified drawings and models are available for a fee. Consult your local Exlar representative for details.

# Tritex II AC Linear Ordering Guide

[Return to Table of Contents](#)

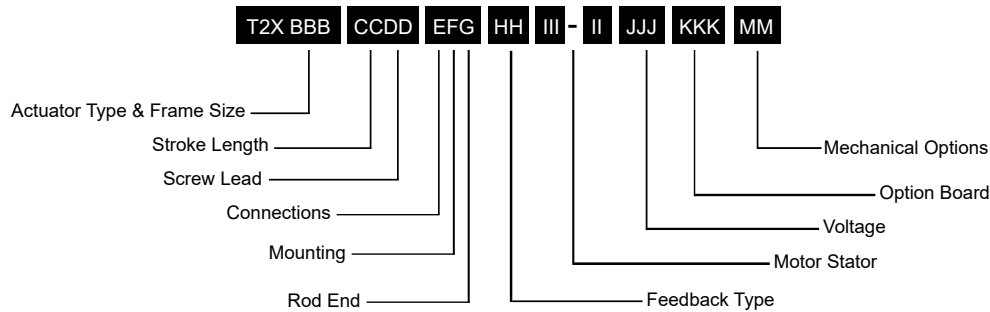

## Actuator Type

T2X = Tritex II Linear Actuator, high mechanical capacity

## BBB = Actuator Frame Size

075 = 75 mm  
090 = 90 mm  
115 = 115 mm

## CC = Stroke Length

03 = 3 inch (76 mm) (N/A T2M/X115)  
04 = 4 inch (102 mm) (T2M/X115 only)  
06 = 6 inch (152 mm)  
10 = 10 inch (254 mm)  
12 = 12 inch (305 mm)  
14 = 14 inch (356 mm)  
18 = 18 inch (457 mm)

## DD = Screw Lead (linear travel per screw revolution)

01 = 0.1 inch (2.54 mm)  
02 = 0.2 inch (5.08 mm)  
05 = 0.5 inch (12.7 mm)  
08 = 0.75 inch (19.05 mm) (T2M/X115 only) <sup>2</sup>

## E = Connections

G = Standard Straight Threaded Port with Internal terminals, M20 x 1.5  
N = NPT Threaded Port via Adapter with Internal Terminals, 1/2" NPT  
I = Intercontec Style - Exlar std, M16/M23 Style Connector

## F = Mounting

C = Rear Clevis  
D = Double Side Mount  
E = Extended Tie Rod  
F = Front Flange  
G = Metric Rear Clevis  
K = Metric Double Side Mount  
M = Metric Extended Tie Rod  
Q = Metric Side Trunnion  
R = Rear Flange  
T = Side Trunnion

## G = Rod End

A = Male Metric Thread <sup>1</sup>  
B = Female Metric Thread <sup>1</sup>  
F = Female US Standard Thread <sup>1</sup>  
M = Male US Standard Thread <sup>1</sup>

## HH = Feedback Type

HD = Analog Hall Device  
IE = Incremental Encoder, 8192 count resolution  
AF = Absolute Feedback

## III-II = Motor Stator, All 8 Pole

T2X075 Stator Specifications  
138-40 = 1 Stack, 230 VAC, 4000 rpm  
238-30 = 2 Stack, 230 VAC, 3000 rpm  
338-20 = 3 Stack, 230 VAC, 2000 rpm

## T2X090 Stator Specifications

138-40 = 1 Stack, 230 VAC, 4000 rpm  
238-40 = 2 Stack, 230 VAC, 4000 rpm  
238-30 = 2 Stack, 230 VAC, 3000 rpm <sup>6</sup>

## T2X115 Stator Specifications

138-30 = 1 Stack, 230 VAC, 3000 rpm  
238-20 = 2 Stack, 230 VAC, 2000 rpm <sup>8</sup>  
238-15 = 2 Stack, 230 VAC, 1500 rpm <sup>6,8</sup>  
(N/A with 0.1" lead)

## JJJ = Voltage

230 = 115-230 VAC, single phase

## KKK = Option Board

SIO = Standard I/O Interconnect  
IA4 = 4-20 mA Analog I/O  
EIP = SIO plus Ethernet/IP w/M12 connector  
EIN = SIO plus Ethernet/IP without M12 connector <sup>7</sup>  
PIO = SIO plus Profinet IO w/M12 connector  
PIN = SIO plus Profinet IO without M12 connector <sup>7</sup>  
TCP = SIO plus Modbus TCP w/M12 connector  
TCN = SIO plus Modbus TCP without M12 connector <sup>10</sup>

## MM = Mechanical Options <sup>3</sup>

AR = External Anti-rotate  
L1/2/3 = External Limit Switches <sup>4</sup>  
RB = Rear Brake  
PB = Protective Bellows (N/A with extended tie rod mounting option)  
SR = Splined Main Rod <sup>5</sup>



For options or specials not listed above or for extended temperature operation, please contact Exlar

## NOTES:

1. Chrome-plated carbon steel. Threads not chrome-plated.
2. 0.75 lead not available above 12 inch stroke.
3. For extended temperature operation consult factory for model number.

4. Limit switch option requires AR option.
5. This option is not sealed and is not suitable for any environment in which contaminants come in contact with actuator and may enter the actuator.

6. N/A with 0.1 inch lead
7. Requires customer supplied Ethernet cable through I/O port for Class 1 Division 2 compliance only.
8. Not available with 4 inch stroke.



# Tritex II AC Rotary Ordering Guide

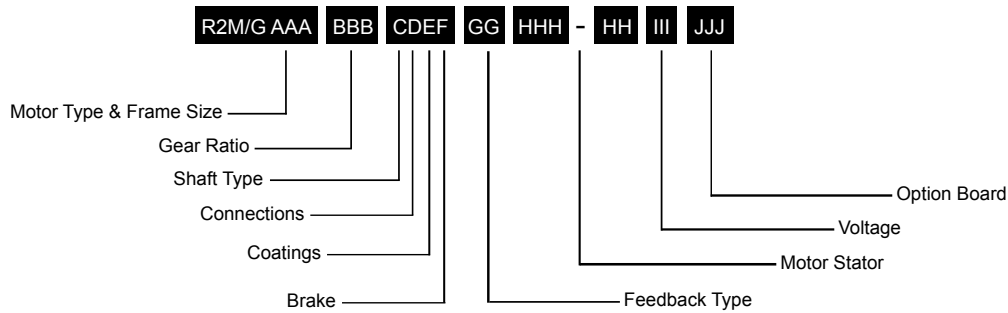

## R2M/G = Motor Type

R2M = Tritex II AC Rotary Motor  
R2G = Tritex II AC Rotary Gearmotor

## AAA = Frame Size

075 = 75 mm  
090 = 90 mm  
115 = 115 mm

## BBB = Gear Ratio

Blank = R2M  
Single Reduction Ratios  
004 = 4:1  
005 = 5:1  
010 = 10:1  
Double Reduction Ratios (N/A on 75 mm)  
016 = 16:1    020 = 20:1  
025 = 25:1    040 = 40:1  
050 = 50:1    100 = 100:1

## C = Shaft Type

K = Keyed

## D = Connections

G = Standard Straight Threaded Port with Internal Terminals, M20 x 1.5  
N = NPT Threaded Port with Internal Terminals, 1/2" NPT  
I = Intercontec style - Exlar Standard, M16/M23 Style Connector

## E = Coating Options

G = Exlar Standard

## F = Brake Option

S = No Brake, Standard  
B = Electric Brake, 24 VDC

## GG = Feedback Type

HD = Analog Hall Device  
IE = Incremental Encoder, 8192 Count Resolution  
AF = Absolute Feedback

## HHH-HH = Motor Stators

R2M/G075 Stator Specifications  
138-40 = 1 Stack, 230 VAC, 4000 rpm  
238-30 = 2 Stack, 230 VAC, 3000 rpm  
338-20 = 3 Stack, 230 VAC, 2000 rpm

R2M/G090 Stator Specifications  
238-40 = 2 Stack, 230 VAC, 4000 rpm  
238-30 = 2 Stack, 230 VAC, 3000 rpm  
338-20 = 3 Stack, 230 VAC, 2000 rpm

R2M/G115 Stator Specifications  
138-30 = 1 Stack, 230 VAC, 3000 rpm  
238-20 = 2 Stack, 230 VAC, 2000 rpm  
238-15 = 2 Stack, 230 VAC, 1500 rpm

## III = Voltage

230 = 115-230 VAC, Single Phase

## JJJ = Option Board

SIO = Standard I/O Interconnect  
IA4 = 4-20 mA Analog I/O  
EIP = SIO plus Ethernet/IP w/M12 connector  
EIN = SIO plus Ethernet/IP without M12 connector<sup>1</sup>  
PIO = SIO plus Profinet IO w/M12 connector  
PIN = SIO plus Profinet IO without M12 connector<sup>1</sup>  
TCP = SIO plus Modbus TCP w/M12 connector  
TCN = SIO plus Modbus TCP without M12 connector<sup>1</sup>



For options or specials not listed above or for extended temperature operation, please contact Exlar

### NOTES:

- Requires customer supplied Ethernet cable through I/O port for Class 1 Division 2 compliance only.
- For extended temperature operation consult factory for model number.

## Cable and Accessories

| Tritex II AC Series Cable & Accessories   | Part No.            |
|---|---------------------|
| <b>Communications Accessories - Tritex uses a 4 pin M8 RS485 communications connector</b>                                 |                     |
| Recommended PC to Tritex communications cable-USB/RS485 to M8 connector - xxx = Length in feet, 006 or 015 only           | CBL-T2USB485-M8-xxx |
| <b>Multi-Drop RS485 Accessories</b>   |                     |
| RS485 splitter - M8 Pin plug to double M8 Socket receptacle   | TT485SP             |
| Multidrop Communications Cable M8 to M8 for use with TT485SP/RS485 splitter - xxx = Length in feet, 006 or 015 only       | CBL-TTDAS-xxx       |
| <b>"G" Connection Accessories</b>   |                     |
| Nickel plated cable gland- M20 x 1.5 - CE shielding- 2 required   | GLD-T2M20 x 1.5     |
| Power cable prepared on one end for use with GLD-T2M20 x 1.5 xxx = Length in ft, Standard lengths 015, 025, 050, 075, 100 | CBL-T2IPC-RAW-xxx   |
| I/O cable prepared on one end for use with GLD-T2M20 x 1.5 xxx = Length in ft, Standard lengths 015, 025, 050, 075, 100   | CBL-T2IOC-RAW-xxx   |
| <b>"N" Connection Accessories</b>   |                     |
| M20 x 1.5 to 1/2" NPT threaded hole adapter for use with conduit  | ADAPT-M20-NPT1/2    |
| <b>"I" Connection</b>   |                     |
| Power cable with M23 6 pin xxx = Length in feet, std lengths 015, 025, 050, 075, 100                                      | CBL-T2IPC-SMI-xxx   |
| I/O cable (75 mm) with M23 19 pin xxx = Length in feet, std lengths 015, 025, 050, 075, 100                               | CBL-TTIOC-SMI-xxx   |
| I/O cable (90 & 115 mm) with M16 19 pin xxx = Length in feet, std lengths 015, 025, 050, 075, 100                         | CBL-T2IOC-SMI-xxx   |
| <b>Multi-Purpose Communications Accessories for long runs, requires terminal block interconnections</b>                   |                     |
| USB to RS485 convertor/cable - USB to RS485 flying leads - xxx = Length in feet, 006 or 015 only                          | CBL-T2USB485-xxx    |
| Communications cable M8 to flying leads cable xxx = Length in feet, standard lengths 015, 025, 050, 075, 100              | CBL-TTCOM-xxx       |
| <b>Option Board Cables and Accessories</b>  |                     |
| EIP, PIO and TCP option Ethernet cable - M12 to RJ45 cable xxx = Length in feet, std lengths 015, 025, 050, 075, 100.     | CBL-T2ETH-R45-xxx   |
| <b>Electrical Accessories</b>   |                     |
| Dynamic Braking Resistor - 100W470hm  | T2BR1               |
| Replacement -AF Battery - used for absolute feedback option   | T2BAT1              |
| Replacement Normally Closed External Limit Switch (Turck Part number BIM-UNT-RP6X)  | 43404               |
| Replacement Normally Open External Limit Switch (Turck Part number BIM-UNT-AP6X)  | 43403               |
| <b>Mechanical Accessories</b>   |                     |
| Clevis Pin for T2X090 male "M" rod end 1/2-20 thread  | CP050               |
| Clevis Pin for T2X115 male "M" rod end 3/4-16 thread  | CP075               |
| Spherical Rod Eye for T2X090 male "M" rod end 1/2-20 thread   | SRM050              |
| Spherical Rod Eye for T2X115 male "M" rod end 3/4-16 thread   | SRM075              |
| Rod Eye for T2X090 male "M" rod end 1/2-20 thread   | REI050              |
| Rod Eye for T2X115 male "M" rod end 3/4-16 thread   | RE075               |
| Rod Clevis for T2X090 male "M" rod end 1/2-20 thread  | RCI050              |
| Rod Clevis for T2X115 male "M" rod end 3/4-16 thread  | RC075               |
| Jam Nut for T2X090 male rod end, 1/2 - 20   | JAM1/2-20-SS        |
| Jam Nut for T2X115 male rod end, 3/4-16   | JAM3/4-16-SS        |



CBL-T2USB485-M8-xxx  
Our recommended communications cable. No special drivers or setup required for use with MS Windows™.



CBL-T2IPC-RAW-xxx  
Use for terminal connections with CBL-TTCOM for long cable runs. No special drivers or setup required for use with MS Windows™.



CBL-TTIOC-SMI-xxx



CBL-TTIPC-SMI-xxx



CBL-TTCOM-xxx  
Use with CBL-T2USB485-xxx for long cable runs.



CBL-TTDAS-xxx  
For use with TT485SP for multi-drop applications.



TT485SP  
RS485 communications splitter. Use to daisy-chain multiple Tritex actuators.

## Tritex II DC

### Linear & Rotary Actuators

No Compromising on Power, Performance or Reliability  
 With forces to approximately 950 lbs (4kN) continuous and 1,300 lbf peak (6 kN), and speeds to 33 in/sec (800 mm/sec), the DC Tritex II linear actuators also offer a benefit that no other integrated product offers: POWER! No longer are you limited to trivial amounts of force, or speeds so slow that many motion applications are not possible. And the new Tritex II with DC power electronics operates with maximum reliability over a broad range of ambient temperatures: -40°C to +65°C. The DC powered Tritex II actuators contain a 750 W servo amplifier and a very capable motion controller. With standard features such as analog following for position, compound moves, move chaining, and individual force/torque control for each move, the Tritex II Series is the ideal solution for most motion applications.

#### Tritex II Models

- TDX high mechanical capacity actuator, 60, and 75 mm
- RDM rotary motor, 60, 75, and 90 mm
- RDG rotary gearmotor, 60, 75, and 90 mm

#### Power Requirements

- DC Power 12-48 VDC nominal
- Connections for external braking resistor

#### Feedback Types

- Analog Hall with 1000 count resolution
- Incremental encoder with 8192 count resolution
- Absolute Feedback (analog hall with multi-turn, battery backup)

#### Connectivity

- Internal terminals accessible through removable cover (75 and 90 mm models)
- Threaded ports for cable glands (75 and 90 mm models)
- Optional connectors - M23 Power - M23 I/O
- M8 connector for RS485
- M12 connector for EtherNet options
- Custom connection options
- Embedded leads

| Technical Characteristics       |   |
|---------------------------------|---|
| Frame Sizes in (mm)             | 2.3 (60), 2.9 (75)                                      |
| Screw Leads in (mm)             | 0.1 (2), 0.2 (5), 0.4 (10), 0.5 (13)                    |
| Standard Stroke Lengths in (mm) | 3 (76), 6 (152), 10 (254), 12 (305), 14 (356), 18 (457) |
| Force Range                     | up to 872 lbf (3879 N)                                  |
| Maximum Speed                   | up to 33.3 in/s (846 mm/s)                              |



| Operating Conditions and Usage |                                    |                                |
|--------------------------------|------------------------------------|--------------------------------|
| <b>Accuracy:</b>               |                                    |                                |
| Screw Lead Error               | in/ft<br>( $\mu\text{m}$ / 300 mm) | 0.001 (25)                     |
| Screw Travel Variation         | in/ft<br>( $\mu\text{m}$ / 300 mm) | 0.0012 (30)                    |
| Screw Lead Backlash            | in                                 | 0.004 (TDX),                   |
| <b>Ambient Conditions:</b>     |                                    |                                |
| Standard Ambient Temperature   | °C                                 | 0 to 65                        |
| Extended Ambient Temperature** | °C                                 | -40 to 65                      |
| Storage Temperature            | °C                                 | -40 to 85                      |
| IP Rating                      |                                    | TDX = IP66S<br>RDM/RDG = IP66S |
| NEMA Ratings                   |                                    | None                           |
| Vibration                      |                                    | 5.0 g rms, 5 to 500 hz         |

\*Ratings at 40°C, operation over 40°C requires de-rating. See page 73.

\*\*Consult Exlar for extended temperature operation.

## Communications & I/O

### Digital Inputs:

9 to 30 VDC Opto-isolated

### Digital Outputs:

30 VDC maximum

100 mA continuous output

Isolated

Short circuit and over temperature protected

### Analog Input DC:

0-10V or +/-10V

0-10V mode, 12 bit resolution

+/-10V mode, 13 bit resolution assignable to Position, Velocity, Torque, or Velocity override command

### Analog Output DC:

0-10V

11 bit resolution

### IA4 option:

4-20 mA input

16 bit resolution

Isolated

Assignable to Position, Velocity, Torque, or Velocity Override command

4-20 mA output

12 bit resolution

Assignable to Position, Velocity, Current, Temperature, etc.

### Standard Communications:

- 1 RS485 port, Modbus RTU, opto-isolated for programming, controlling and monitoring

| Tritex II DC I/O            |   |                            |
|-----------------------------|---|----------------------------|
|                             | 60/75/90 mm frame with SIO, EIP, PIO, TCP | 60/75/90 mm frame with IA4 |
| Isolated digital inputs     | 8   | 4                          |
| Isolated digital outputs    | 4   | 3                          |
| Analog input, non isolated  | 1   | 0                          |
| Analog output, non isolated | 1   | 0                          |
| Isolated 4-20ma input       | 0   | 1                          |
| Isolated 4-20ma output      | 0   | 1                          |

The IO count and type vary with the actuator model and option module selected.

All models include isolated digital IO, and an isolated RS485 communication port when using Modbus RTU protocol.

## Product Features

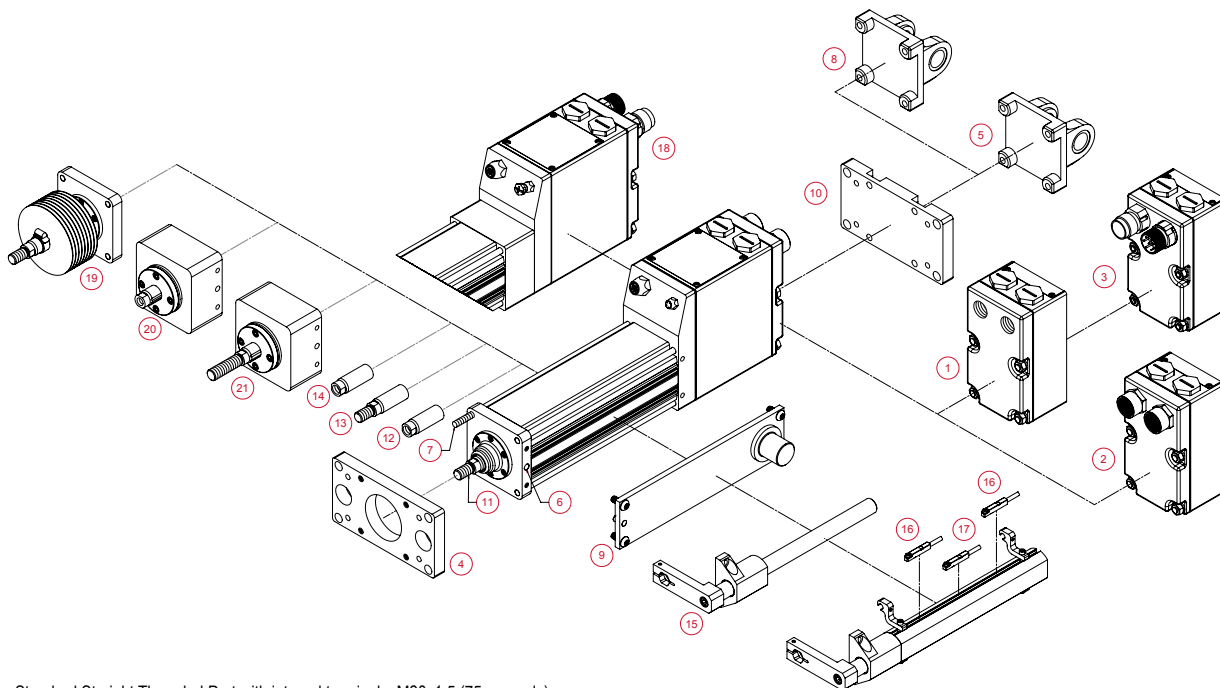
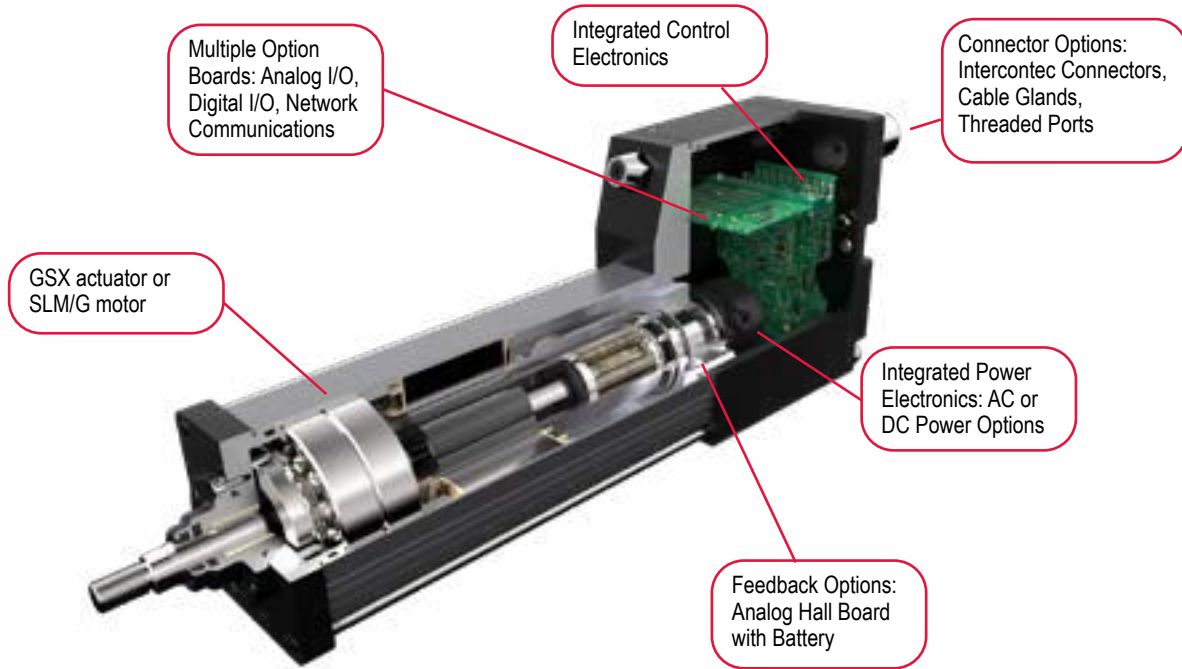

- 1 - Standard Straight Threaded Port with internal terminals, M20x1.5 (75 mm only)
- 2 - NPT Threaded Port via Adapter with Internal Terminals, 1/2" NPT (75 mm only)
- 3 - Interconnect Style - Exlar standard, M23 Style Connector
- 4 - Front Flange
- 5 - Rear Clevis
- 6 - Double Side Mount and Metric Double Side Mount
- 7 - Extended Tie Rod and Metric Extended Tie Rod
- 8 - Metric Rear Clevis
- 9 - Metric Side Trunnion and Side Trunnion
- 10 - Female Metric Thread
- 11 - Male Metric Thread
- 12 - Female Metric Thread
- 13 - Male US Standard Thread
- 14 - Female US Standard Thread
- 15 - External Anti-rotate
- 16 - External Limit Switch - N.C., PNP
- 17 - External Limit Switch - N.O., PNP
- 18 - Rear Brake
- 19 - Protective Bellows
- 20 - Splined Main Rod - Female
- 21 - Splined Main Rod - Male

[Return to Table of Contents](#)

## Industries and Applications

Hydraulic cylinder replacement  
Ball screw replacement  
Pneumatic cylinder replacement

### Process Control

Oil & Gas Wellhead Valve Control  
Pipeline Valve Control  
Damper Control  
Knife Valve Control  
Chemical pumps

### Entertainment / Simulation

Ride Motion Bases  
Animatronics

### Mobile Equipment

Unmanned Vehicles

Since no fluids and associated equipment (pumps, compressors, filters, accumulators, hose/tubing, oil testing, etc.) are required, electromechanical actuators offer greater energy efficiency, less environmental impact and lower total life-cycle cost.

The Tritex II Series DC actuators integrate a DC powered servo drive, digital position controller, brushless motor, and linear actuator in a compact, sealed package making it perfect for environments where AC power is difficult to achieve.

## Mechanical Specifications

### TDX060

|  |   | Stator  | 1 Stack                  | 2 Stack                 | 3 Stack       |
|--|---|---|--------------------------|-------------------------|---------------|
| Lead                                     |   | RPM @ 48 VDC  | 5000                     | 5000                    | 4000          |
| 0.1                                      | Continuous Force                                | lbf (N)   | 339 (1508)               | 528 (2349)              | N/A           |
|  | Peak Force                                      | lbf (N)   | 641 (2851)               | 666 (2963)              | N/A           |
|  | Max Speed @ 48 VDC                              | in/sec (mm/sec)   | 8.33 (211.6)             | 8.33 (211.6)            | N/A           |
|  | TDX - C <sub>a</sub> (Dynamic Load Rating)      | lbf (N)   | 2075 (9230)              |                         | NA            |
| 0.2                                      | Continuous Force                                | lbf (N)   | 180 (801)                | 280 (1246)              | 347 (1544)    |
|  | Peak Force                                      | lbf (N)   | 340 (1512)               | 354 (1575)              | 454 (2019)    |
|  | Max Speed @ 48 VDC                              | in/sec (mm/sec)   | 16.67 (423.4)            | 16.67 (423.4)           | 13.33 (338.6) |
|  | TDX - C <sub>a</sub> (Dynamic Load Rating)      | lbf (N)   | 1540 (6850)              |                         |               |
| 0.4                                      | Continuous Force                                | lbf (N)   | 95 (423)                 | 148 (658)               | 184 (818)     |
|  | Peak Force                                      | lbf (N)   | 180 (801)                | 187 (832)               | 240 (1068)    |
|  | Max Speed @ 48 VDC                              | in/sec (mm/sec)   | 33.33 (847)              | 33.33 (847)             | 26.67 (677.4) |
|  | TDX - C <sub>a</sub> (Dynamic Load Rating)      | lbf (N)   | 1230 (5471)              |                         |               |
| Drive Current @ Continuous Force         | Amps  | 14.75   | 21.5                     | 21.5                    |               |
| Available Stroke Lengths                 | in (mm)   | 3 (75), 6 (150), 10 (254), 12 (300)   |                          |                         |               |
| Inertia (zero stroke)                    | lb-in-s <sup>2</sup> / Kg-m <sup>2</sup>        | 0.0007758 (0.0000008766)  | 0.0008600 (0.0000009717) | 0.0009442 (0.000001067) |               |
| Inertia Adder (per unit of stroke)       | lb-in-s <sup>2</sup> /in/ Kg-m <sup>2</sup> /in | 0.00004667 (0.0000005273)   |                          |                         |               |
| Approximate Weight                       | lb (kg)   | 4 lbs – 3 in stroke, 1 stack, add 1 lb per inch of stroke, add 3 lbs per stack, add 3 lbs for brake.<br>(1.8 kg – 75 mm stroke, 1 stack, add 0.5 kg per 25 mm of stroke, add 1.4 kg per stack, add 1.4 kg for brake.) |                          |                         |               |
| Operating Temperature Range**            |   | -20 to 65° C (-40° C available, consult Exlar)  |                          |                         |               |
| Maximum Continuous Power Supply Current† | Amps  | 11  | 15                       | 15                      |               |

†Power supply current is based on software current limit, not thermal limit. Consideration for peak current should also be considered when sizing power supplies.

\*\*Rating based on 40° C ambient conditions.

## TDX075

|  |   | Stator  | 1 Stack              | 2 Stack              | 3 Stack       |
|--|---|---|----------------------|----------------------|---------------|
| Lead                                     |   | RPM @ 48 VDC  | 3000                 | 3000                 | 2000          |
| 0.1                                      | Continuous Force                                | lbf (N)   | 613 (2727)           | 872 (3879)           | NA            |
|  | Peak Force                                      | lbf (N)   | 884 (3932)           | 1190 (5293)          | NA            |
|  | Max Speed @ 48 VDC                              | in/sec (mm/sec)   | 5.00 (127)           | 5.00 (127)           | NA            |
|  | TDX - C <sub>a</sub> (Dynamic Load Rating)      | lbf (N)   | 5516 (24536)         |                      | NA            |
| 0.2                                      | Continuous Force                                | lbf (N)   | 347 (1544)           | 494 (2197)           | 774 (3443)    |
|  | Peak Force                                      | lbf (N)   | 501 (2229)           | 674 (2998)           | 1095 (4871)   |
|  | Max Speed @ 48 VDC                              | in/sec (mm/sec)   | 10.00 (254)          | 10.00 (254)          | 6.67 (169.4)  |
|  | TDX - C <sub>a</sub> (Dynamic Load Rating)      | lbf (N)   | 5800 (25798)         |                      |               |
| 0.5                                      | Continuous Force                                | lbf (N)   | 147 (654)            | 209 (930)            | 328 (1459)    |
|  | Peak Force                                      | lbf (N)   | 212 (943)            | 286 (1272)           | 464 (2064)    |
|  | Max Speed @ 48 VDC                              | in/sec (mm/sec)   | 25.00 (635)          | 25.00 (635)          | 16.67 (423.4) |
|  | TDX - C <sub>a</sub> (Dynamic Load Rating)      | lbf (N)   | 4900 (21795)         |                      |               |
| Drive Current @ Continuous Force         | Amps  | 18.5  | 22.5                 | 22.5                 |               |
| Available Stroke Lengths                 | in (mm)   | 3 (75), 6 (150), 10 (254), 12 (300), 14 (355), 18 (450)   |                      |                      |               |
| Inertia (zero stroke)                    | lb-in-s <sup>2</sup> / Kg-m <sup>2</sup>        | 0.01132 (0.000012790)   | 0.01232 (0.00001392) | 0.01332 (0.00001505) |               |
| Inertia Adder (per unit of stroke)       | lb-in-s <sup>2</sup> /in/ Kg-m <sup>2</sup> /in | 0.0005640 (0.0000006372)  |                      |                      |               |
| Approximate Weight                       | lb (kg)   | 11 lbs – 3 in stroke, add 1 lb per inch of stroke, add 3 lbs per stack, add 3 lbs for brake.<br>(5 kg – 75 mm stroke, 1 stack, add 0.5 kg per 25 mm of stroke, add 1.4 kg per stack, add 1.4 kg for brake.) |                      |                      |               |
| Operating Temperature Range**            |   | -20 to 65° C (-40° C available, consult Exlar)  |                      |                      |               |
| Maximum Continuous Power Supply Current* | Amps  | 15  | 18                   | 18                   |               |

\*Power supply current is based on software current limit, not thermal limit. Consideration for peak current should also be considered when sizing power supplies.

\*\*Rating based on 40° C ambient conditions.

### DEFINITIONS:

**Continuous Force:** The linear force produced by the actuator at continuous motor torque.

**Peak Force:** The linear force produced by the actuator at peak motor torque.

**Max Speed:** The maximum rated speed produced by the actuator at rated voltage.

**C<sub>a</sub> (Dynamic Load Rating):** A design constant used in calculating the estimated travel life of the roller screw.

## Estimated Service Life

TDX060 Estimated  $L_{10}$  Travel Life

TDX075 Estimated  $L_{10}$  Travel Life

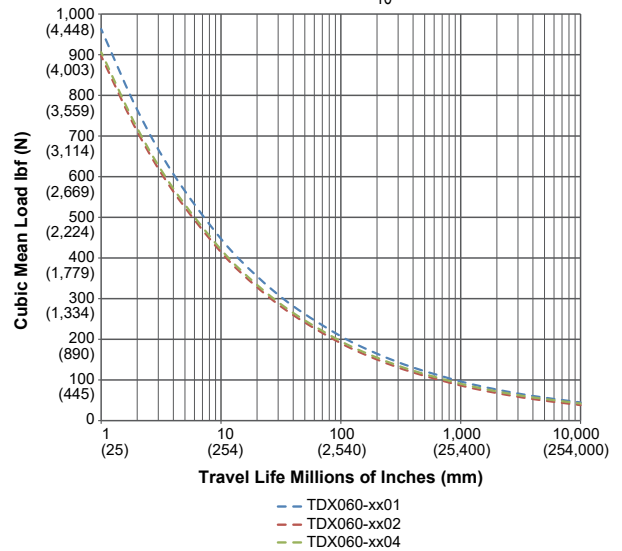

The  $L_{10}$  expected life of a roller screw linear actuator is expressed as the linear travel distance that 90% of properly maintained roller screws are expected to meet or exceed. For higher than 90% reliability, the result should be multiplied by the following factors: 95% x 0.62; 96% x 0.53; 97% x 0.44; 98% x 0.33; 99% x 0.21. This is not a guarantee; these charts should be used for estimation purposes only.

The underlying formula that defines this value is:

Travel life in millions of inches, where:

$C_a$  = Dynamic load rating (lbf)

$F_{cml}$  = Cubic mean applied load (lbf)

$\ell$  = Roller screw lead (inches)

$$L_{10} = \left( \frac{C_a}{F_{cml}} \right)^3 \times \ell$$

*All curves represent properly lubricated and maintained actuators.*

## Speed vs. Force Curves

### Temperature Derating

The speed/torque curves are based on 40° C ambient conditions. The actuators may be operated at ambient temperatures up to 65° C. Use the curve (shown right) for continuous torque/force deratings above 40° C.

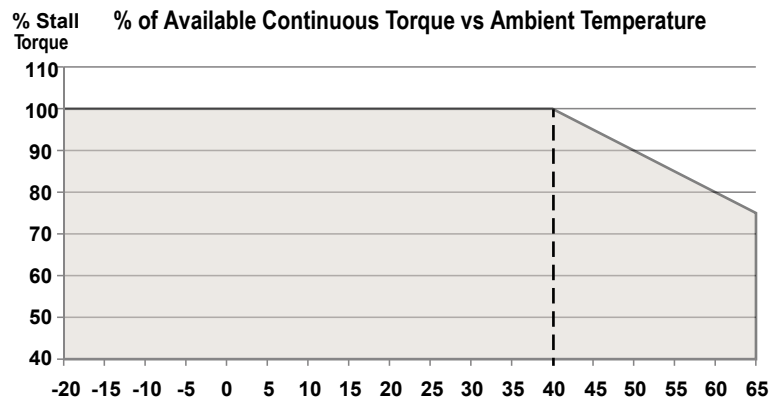



# Tritex II DC Linear

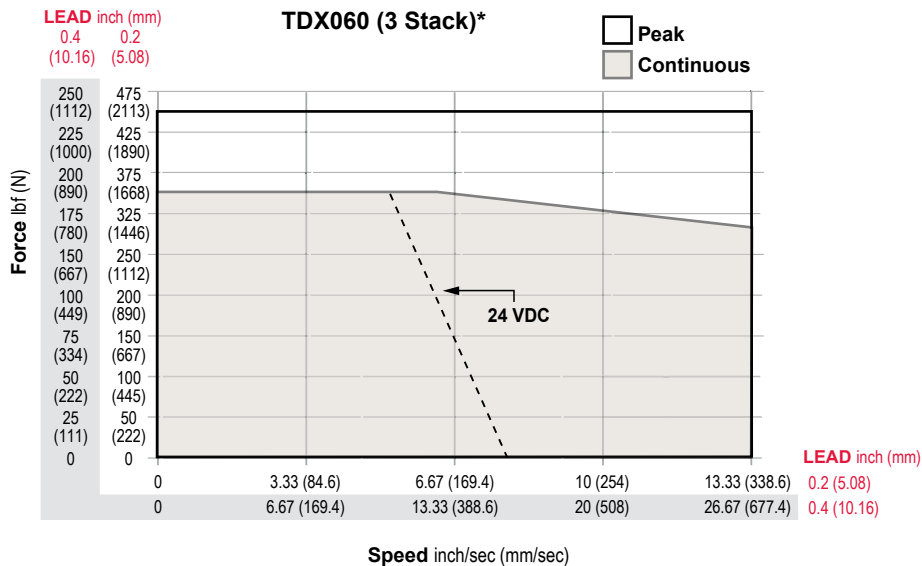
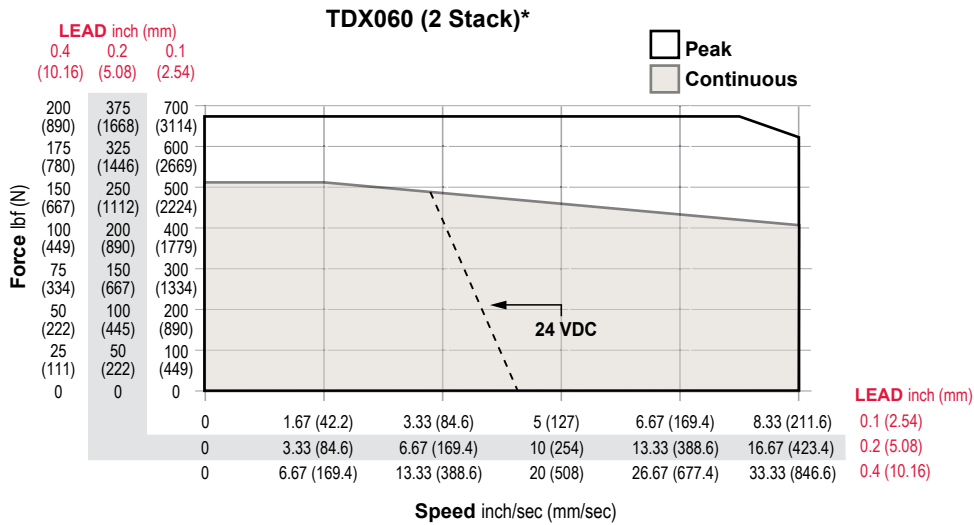
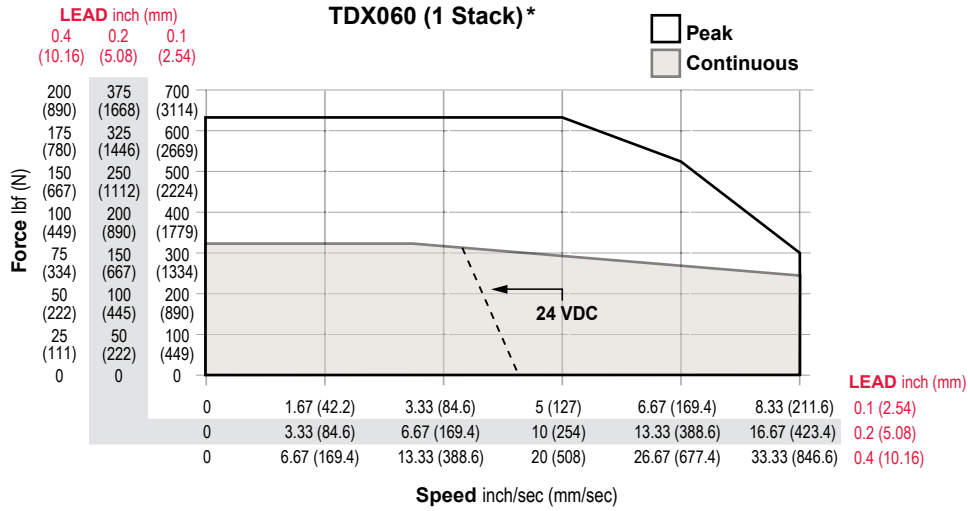

\*Test data derived using NEMA recommended aluminum heatsink 10" x 10" x 3/8" at 40°C ambient.

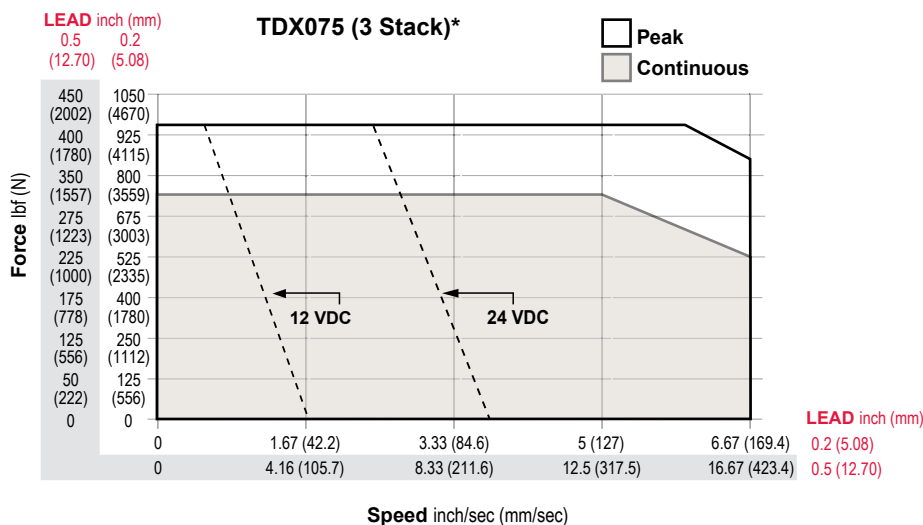
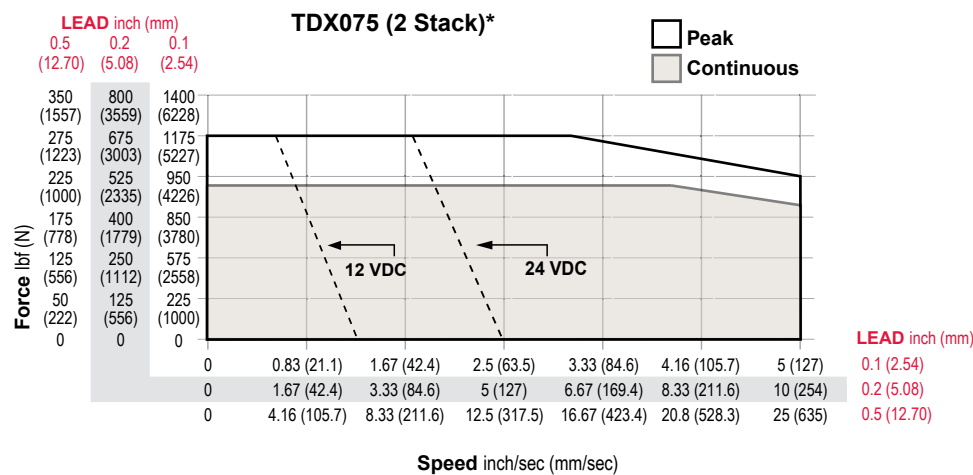
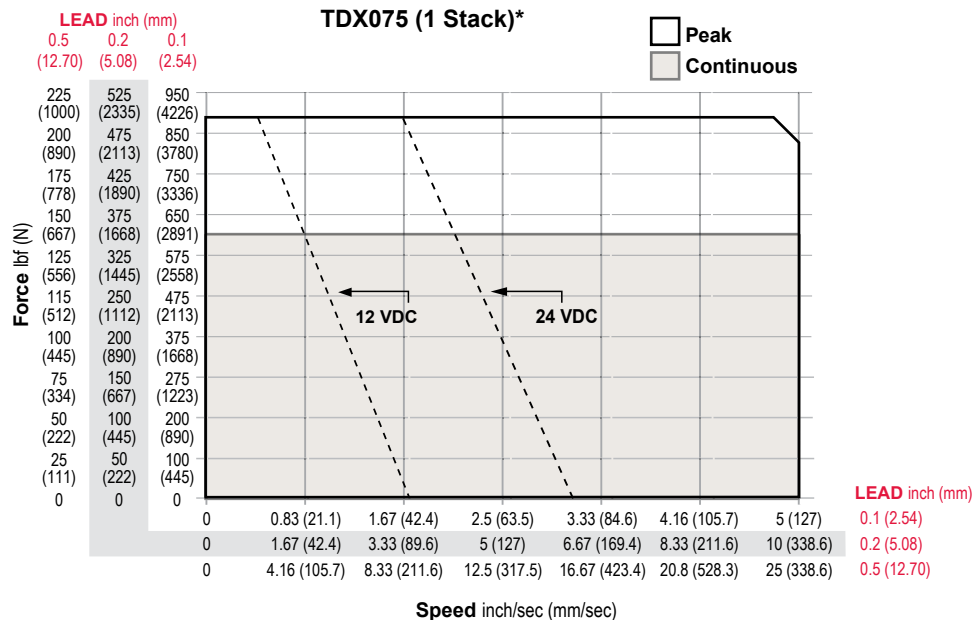

\*Test data derived using NEMA recommended aluminum heatsink 10" x 10" x 3/8" at 40°C ambient.

## Options

### **AR = External Anti-rotate Assembly**

This option provides a rod and bushing to restrict the actuator rod from rotating when the load is not held by another method. Shorter actuators have single sided anti-rotation attachments. Longer lengths require attachments on both sides for proper operation. For AR dimensions, see page 79.

### **L1, L2, L3 = Adjustable External Travel Switches**

This option allows up to 3 external switches to be included. These switches provide travel indication to the controller and are adjustable. See drawing on page 29. Must purchase external anti-rotate with this option.

### **RB = Rear Electric Brake**

This option provides an internal holding brake. The brake is spring activated and electrically released.

### **PB = Protective Bellows**

This option provides an accordion style protective bellows to protect the main actuator rod from damage due to abrasives or other contaminants in the environment in which the actuator must survive. The standard material of this bellows is S2 Neoprene Coated Nylon, Sewn Construction. This standard bellows is rated for environmental temperatures of -40 to 250 degrees F. Longer strokes may require the main rod of the actuator to be extended beyond standard length. Not available with extended tie rod mounting option. Please contact your local sales representative.

### **SR = Splined Main Rod**

A ball spline shafting main rod with a ball spline nut that replaces the standard front seal and bushing assembly. This rod restricts rotation without the need for an external mechanism. The rod diameter will be the closest metric equivalent to our standard rod sizes. Since this option is NOT sealed, it is not suitable for environments in which contaminants may enter the actuator.

Note: Adding this option affects the overall length and mounting dimensions.

## Dimensions

### TDX060 Double Side Mount or Extended Tie Rod Mount

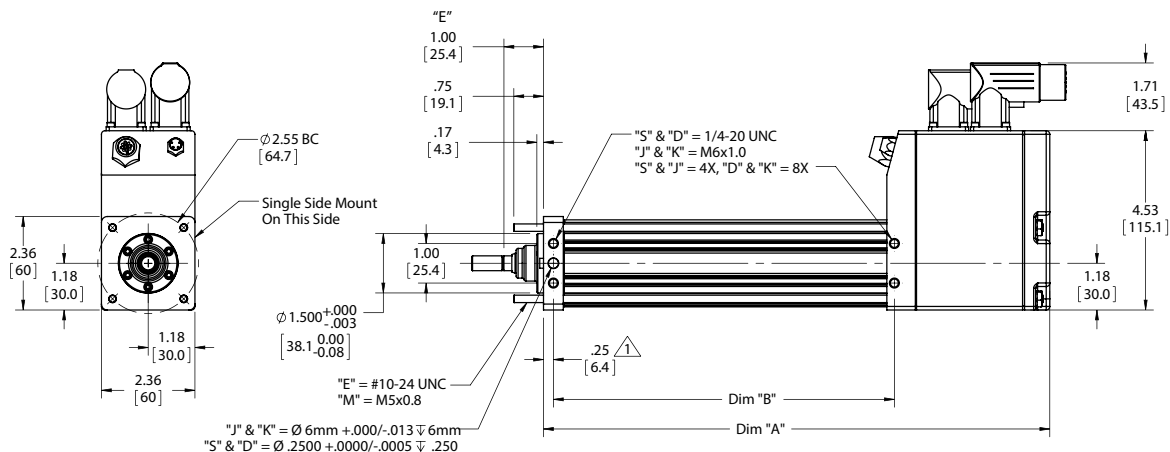

### TDX060 Side Trunnion Mount or Rear Clevis Mount

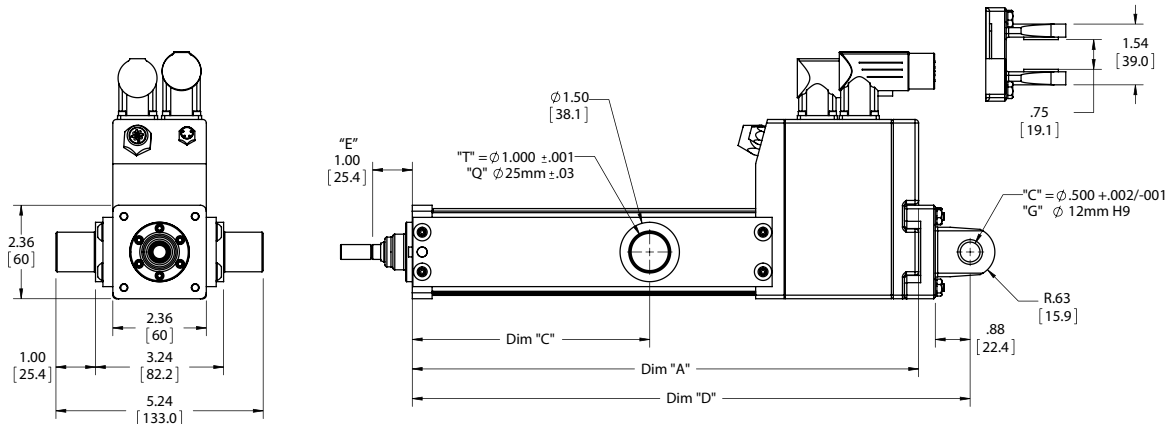

### TDX060 Front, Rear, or Front and Rear Flange Mount

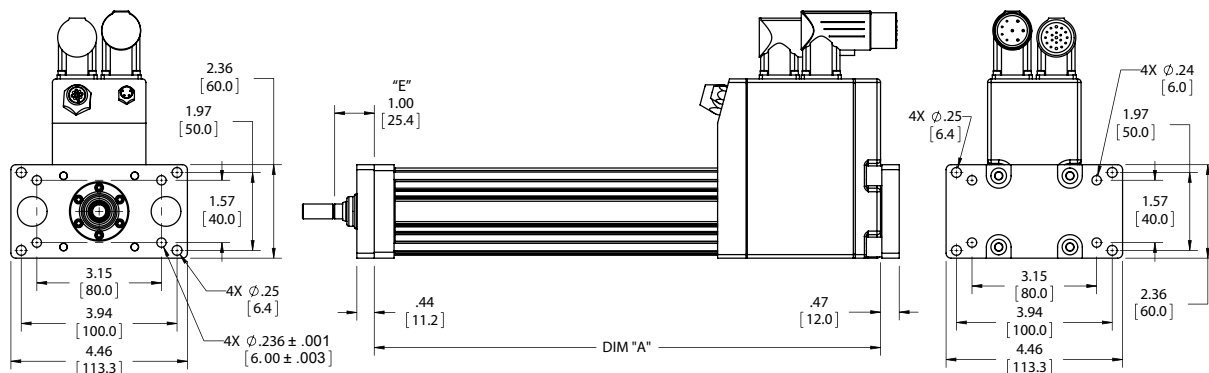

| DIM | 3 inch (75 mm) stroke in (mm) | 6 inch (150 mm) stroke in (mm) | 10 inch (250 mm) stroke in (mm) | 12 inch (300 mm) stroke in (mm) |
|-----|-------------------------------|--------------------------------|---------------------------------|---------------------------------|
| A   | 9.79 (248.7)                  | 12.79 (324.9)                  | 16.79 (426.5)                   | 18.79 (477.3)                   |
| B   | 5.62 (142.8)                  | 8.62 (218.9)                   | 12.62 (320.6)                   | 14.62 (371.4)                   |
| C   | 3.00 (76.2)                   | 6.00 (152.4)                   | 10.00 (254.0)                   | 12.00 (304.8)                   |
| D   | 11.10 (281.9)                 | 14.10 (358.1)                  | 18.10 (459.7)                   | 20.10 (510.5)                   |

\* Add 1.75 inches to dimensions "A", "B" and "D" if ordering a brake. Add .50 inches to dimensions "A", "C" and "D" and dimension if ordering a splined  $\Delta$  main rod.

\*\*Add 2 inches (50.8 mm) to "E" if ordering protective bellows.

Pre-sale drawings and models are representative and are subject to change. Certified drawings and models are available for a fee. Consult your local Exlar representative for details.

## TDX075 Double Side Mount or Extended Tie Rod Mount

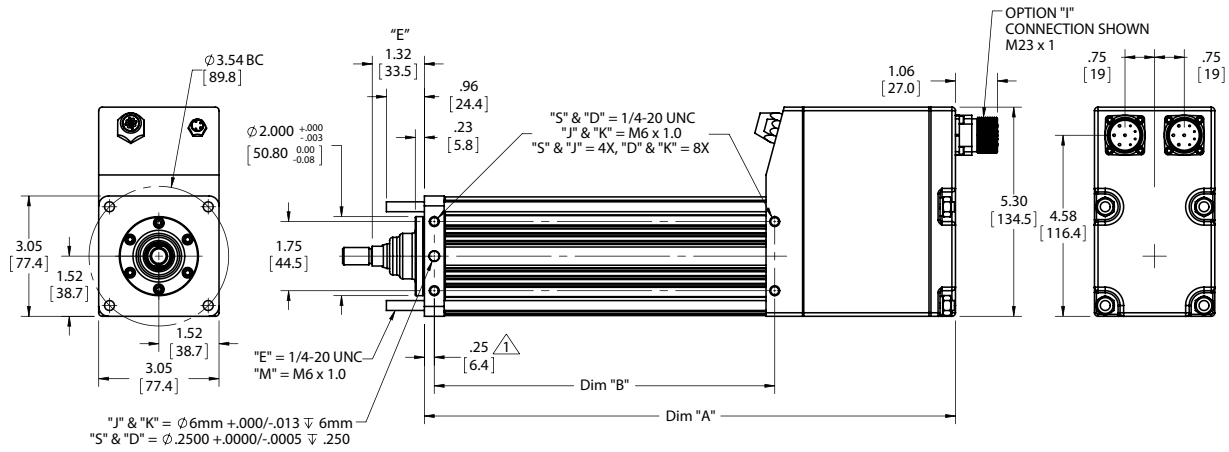

## TDX075 Side Trunnion Mount or Rear Clevis Mount

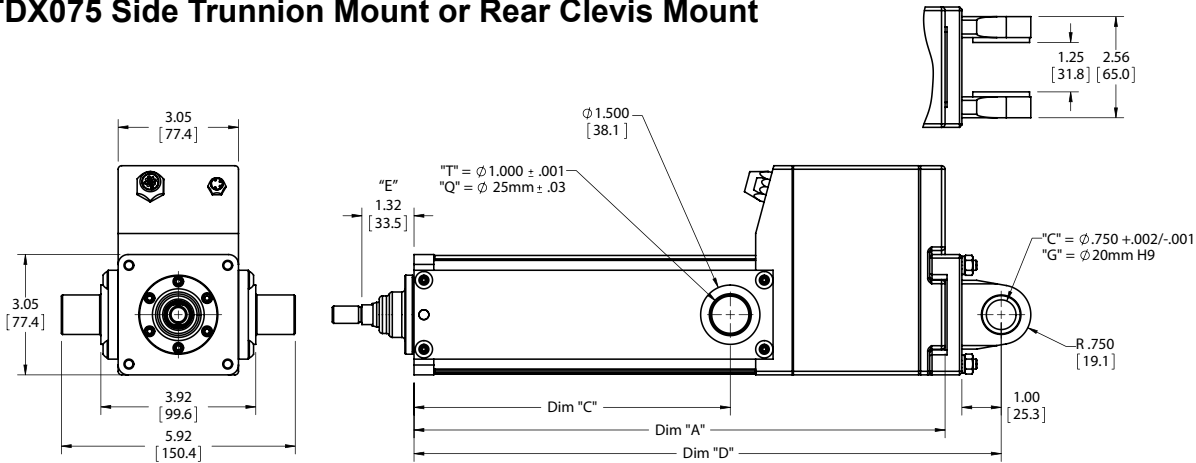

## TDX075 Front, Rear, or Front and Rear Flange Mount

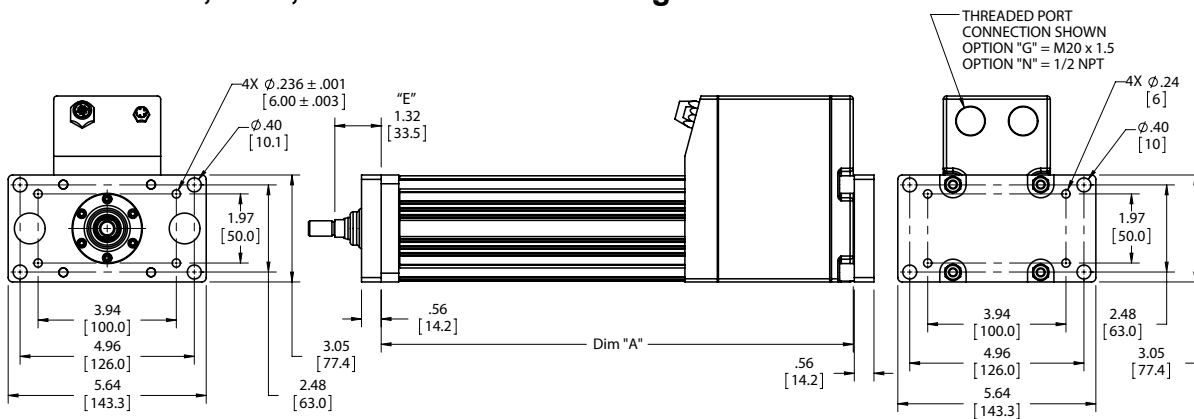

| DIM | 3 inch (75 mm) stroke in (mm) | 6 inch (150 mm) stroke in (mm) | 10 inch (250 mm) stroke in (mm) | 12 inch (300 mm) stroke in (mm) | 14 inch (350 mm) stroke in (mm) | 18 inch (450 mm) stroke in (mm) |
|-----|-------------------------------|--------------------------------|---------------------------------|---------------------------------|---------------------------------|---------------------------------|
| A   | 10.98 (278.9)                 | 13.45 (341.6)                  | 17.95 (455.9)                   | 19.95 (506.7)                   | 21.95 (557.5)                   | 25.95 (659.1)                   |
| B   | 6.15 (156.2)                  | 8.62 (218.9)                   | 13.12 (333.2)                   | 15.12 (384.0)                   | 17.12 (434.8)                   | 21.12 (536.4)                   |
| C   | 5.38 (136.7)                  | 8.00 (203.2)                   | 10.00 (254.0)                   | 12.00 (304.8)                   | 14.00 (355.6)                   | 18.00 (457.2)                   |
| D   | 12.40 (315.0)                 | 14.87 (377.7)                  | 19.37 (492.0)                   | 21.37 (542.8)                   | 23.37 (593.6)                   | 27.37 (695.2)                   |

\* Add 1.61 inches to dimensions "A", "B" and "D" if ordering a brake. Add 1.2 inches to dimensions "A", "C" and "D" and dimension if ordering a splined  $\Delta$  main rod.

\*\*Add 2 inches (50.8 mm) to "E" if ordering protective bellows.

Pre-sale drawings and models are representative and are subject to change. Certified drawings and models are available for a fee. Consult your local Exlar representative for details.

## Anti-Rotate Option

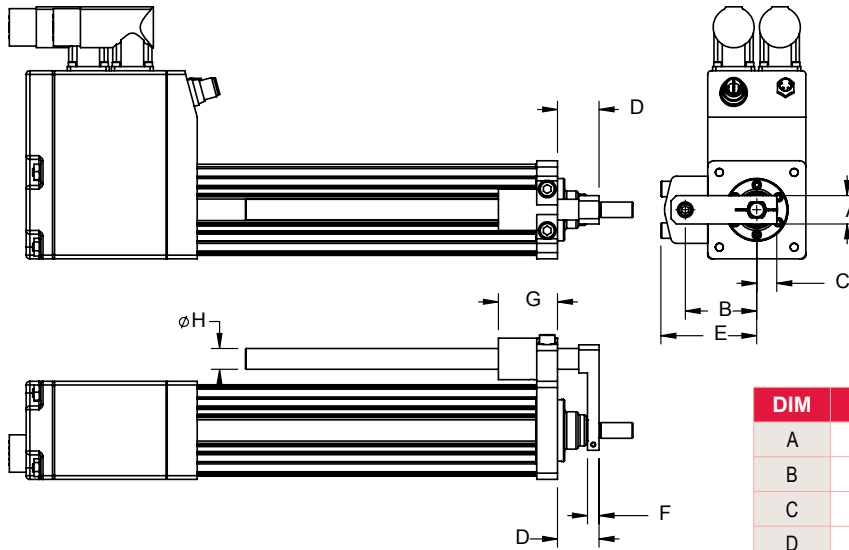

| DIM | TDX060      | TDX075      |
|-----|-------------|-------------|
| A   | 0.68 (17.3) | 0.82 (20.9) |
| B   | 1.72 (43.7) | 2.21 (56.1) |
| C   | 0.48 (12.2) | 0.60 (15.2) |
| D   | 1.00 (25.4) | 1.32 (33.5) |
| E   | 2.31 (58.7) | 2.71 (68.8) |
| F   | 0.28 (7.1)  | 0.39 (9.9)  |
| G   | 1.43 (36.3) | 1.70 (43.2) |
| ØH  | 0.50 (12.7) | 0.63 (15.9) |

## Actuator Rod End Option

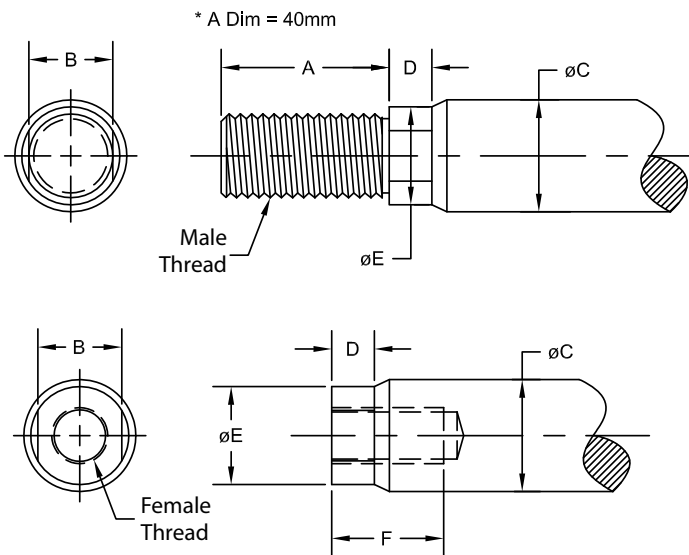

| DIM           | TDX060            | TDX075                     |
|---------------|-------------------|----------------------------|
| A             | 0.813 (20.7)      | 0.750 (19.1)               |
| B             | 0.375 (9.5)       | 0.500 (12.7)               |
| ØC            | 0.500 (12.7)      | 0.625 (15.9)               |
| D             | 0.200 (5.1)       | 0.281 (7.1)                |
| ØE            | 0.440 (11.2)      | 0.562 (14.3)               |
| F             | 0.750 (19.1)      | 0.750 (19.1)               |
| Male-Inch     | 3/8-24<br>UNF-2A  | 7/16-20<br>UNF-2A          |
| Male-Metric   | M8 x 1-6g         | M12 x 1.75-6g <sup>*</sup> |
| Female-Inch   | 5/16-24<br>UNF-2B | 7/16-20<br>UNF-2B          |
| Female-Metric | M8 x 1-6h         | M10 x 1.5-6h               |

<sup>\*</sup>When ordering the male M12x1.75 main rod for the TDM/X075 dimension "A" will be 1.57 in (40 mm)

## Clevis Pin

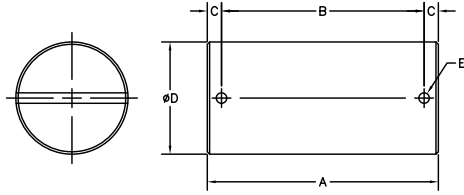

| DIM | TDX060   | TDX075                       |
|-----|--|------------------------------|
|     | CP050 in (mm)<br>Rear Clevis,<br>RE050 & RC050 | CP075 in (mm)<br>Rear Clevis |
| A   | 2.28 (57.9)                                    | 3.09 (78.5)                  |
| B   | 1.94 (49.28)                                   | 2.72 (69.1)                  |
| C   | 0.17 (4.32)                                    | 1.19 (4.82)                  |
| ØD  | 0.50 (12.7)<br>-0.001/-0.002                   | 0.75 (19.1)<br>-0.001/-0.002 |
| ØE  | 0.095 (2.41)                                   | 0.14 (3.56)                  |

## Spherical Rod Eye

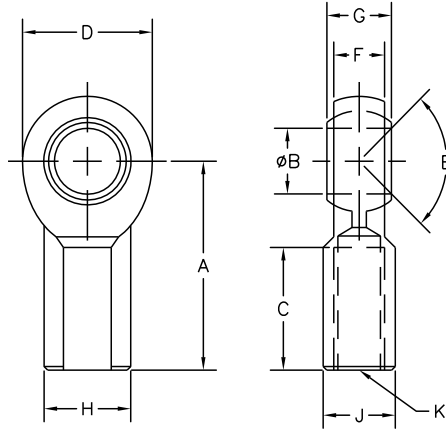

| DIM | TDX060         | TDX075         |
|-----|----------------|----------------|
|     | SRM038 in (mm) | SRM044 in (mm) |
| A   | 1.625 (41.3)   | 1.81 (46.0)    |
| ØB  | 0.375 (9.525)  | 0.438 (11.13)  |
| C   | 0.906 (23.0)   | 1.06 (26.9)    |
| D   | 1.0 (25.6)     | 1.13 (28.7)    |
| E   | 12 Deg         | 14 Deg         |
| F   | 0.406 (10.3)   | 0.44 (11.1)    |
| G   | 0.500 (12.7)   | 0.56 (14.2)    |
| H   | 0.688 (17.7)   | 0.75 (19.1)    |
| J   | 0.562 (14.3)   | 0.63 (16.0)    |
| K   | 3/8-24         | 7/16-20        |

## Rod Eye

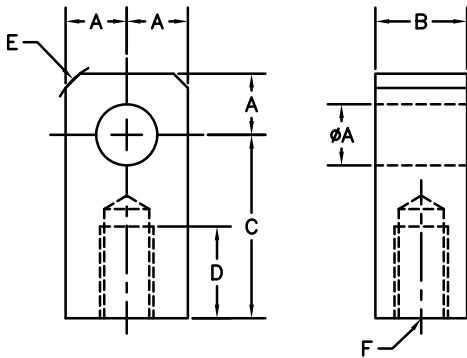

| DIM | TDX060           | TDX075        |
|-----|------------------|---------------|
|     | RE038 in (mm)    | RE050 in (mm) |
| ØA  | 0.50 (12.7)      | 0.50 (12.7)   |
| B   | 0.560 (14.2)     | 0.75 (19.1)   |
| C   | 1.000 (25.4)     | 1.50 (38.1)   |
| D   | 0.500 (12.7)     | 0.75 (19.1)   |
| E   | 0.25 x 45 (6.35) | 0.63 (15.9)   |
| F   | 3/8-24           | 7/16-20       |

## Rod Clevis

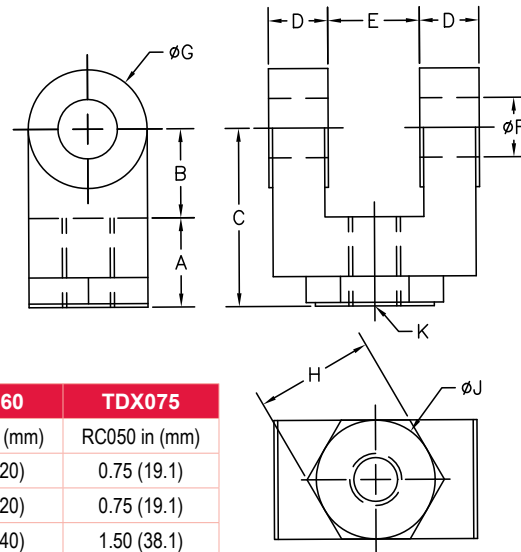

| DIM | TDX060        | TDX075        |
|-----|---------------|---------------|
|     | RC038 in (mm) | RC050 in (mm) |
| A   | 0.787 (20)    | 0.75 (19.1)   |
| B   | 0.787 (20)    | 0.75 (19.1)   |
| C   | 1.574 (40)    | 1.50 (38.1)   |
| D   | 0.183 (4.65)  | 0.50 (12.7)   |
| E   | 0.375 (9.5)   | 0.765 (19.43) |
| ØF  | 0.375 (9.5)   | 0.50 (12.7)   |
| ØG  | 0.75 (19.1)   | 1.00 (25.4)   |
| H   | N/A           | 1.00 (25.4)   |
| ØJ  | N/A           | 1.00 (25.4)   |
| K   | 3/8-24        | 7/16-20       |

[Return to Table of Contents](#)

## Mechanical Specifications

### RDM/G060

| Rotary Motor Torque and Speed Ratings    |  |             |             |           |
|--|--|-------------|-------------|-----------|
|  | Stator   | 1 Stack     | 2 Stack     | 3 Stack   |
|  | RPM at 48 VDC                                  | 5000        | 5000        | 4000      |
| Continuous Torque                        | lbf-in (Nm)                                    | 6.8 (0.76)  | 10.5 (1.18) | 13 (1.47) |
| Peak Torque                              | lbf-in (Nm)                                    | 12.8 (1.44) | 13.3 (1.5)  | 17 (1.92) |
| Drive Current @ Continuous Torque        | Amps   | 14.8        | 21.5        | 21.5      |
| Operating Temperature Range**            | -20 to 65° C (-40° C available, consult Exlar) |             |             |           |
| Maximum Continuous Power Supply Current* | Amps   | 8           | 11          | 13        |

\*Power supply current is based on software current limit, not thermal limit. Consideration for peak current should also be considered when sizing power supplies. For output torque of RDG gearmotors, multiply by ratio and efficiency. Please note maximum allowable output torques found at bottom of page.

\*\*Ratings based on 40° C ambient conditions.

| Inertia                            |  |                     |                     |                     |
|------------------------------------|--|---------------------|---------------------|---------------------|
|                                    | Stator   | 1 Stack             | 2 Stack             | 3 Stack             |
| RDM Motor Armature Inertia (+/-5%) | lbf-in-sec <sup>2</sup><br>(kg-cm <sup>2</sup> ) | 0.000237<br>(0.268) | 0.000413<br>(0.466) | 0.000589<br>(0.665) |
| RDG Gearmotor Armature Inertia*    | lbf-in-sec <sup>2</sup><br>(kg-cm <sup>2</sup> ) | 0.000226<br>(0.255) | 0.000401<br>(0.453) | 0.000576<br>(0.651) |

\*Add armature inertia to gearing inertia for total inertia.

| L <sub>10</sub> Radial Load and Bearing Life |               |              |              |              |             |             |
|--|---------------|--------------|--------------|--------------|-------------|-------------|
| RPM  | 50            | 100          | 250          | 500          | 1000        | 3000        |
| RDM060<br>lbf (N)                            | 250<br>(1112) | 198<br>(881) | 148<br>(658) | 116<br>(516) | 92<br>(409) | 64<br>(285) |
| RDG060<br>lbf (N)                            | 189<br>(841)  | 150<br>(667) | 110<br>(489) | 88<br>(391)  | 70<br>(311) | 48<br>(214) |

Side load ratings shown above are for 10,000 hour bearing life at 25 mm from motor face at given rpm.

| Gearmotor Mechanical Ratings |       |   |   |                      |                      |
|------------------------------|-------|---|---|----------------------|----------------------|
| Model                        | Ratio | Maximum Allowable Output Torque-Set by User lbf-in (Nm) | Output Torque at Motor Speed for 10,000 Hour Life |                      |                      |
|                              |       |   | 1000 RPM lbf-in (Nm)                              | 3000 RPM lbf-in (Nm) | 5000 RPM lbf-in (Nm) |
| RDG060-004                   | 4:1   | 603 (68.1)  | 144 (16.2)  | 104 (11.7)           | 88 (9.9)             |
| RDG060-005                   | 5:1   | 522 (58.9)  | 170 (19.2)  | 125 (14.1)           | 105 (11.9)           |
| RDG060-010                   | 10:1  | 327 (36.9)  | 200 (22.6)  | 140 (15.8)           | 120 (13.6)           |
| RDG060-016                   | 16:1  | 603 (68.1)  | 224 (25.3)  | 160 (18.1)           | 136 (15.4)           |
| RDG060-020                   | 20:1  | 603 (68.1)  | 240 (27.1)  | 170 (19.2)           | 146 (16.5)           |
| RDG060-025                   | 25:1  | 522 (58.9)  | 275 (31.1)  | 200 (22.6)           | 180 (20.3)           |
| RDG060-040                   | 40:1  | 603 (68.1)  | 288 (32.5)  | 208 (23.5)           | 180 (20.3)           |
| RDG060-050                   | 50:1  | 522 (58.9)  | 340 (38.4)  | 245 (27.7)           | 210 (23.7)           |
| RDG060-100                   | 100:1 | 327 (36.9)  | 320 (36.1)  | 280 (31.6)           | 240 (27.1)           |

Two torque ratings for the RDG gearmotors are given in the table above. The left hand columns give the maximum (peak) allowable output torque for the indicated ratios of each size RDG gearmotor. This is not the rated output torque of the motor multiplied by the ratio of the reducer.

It is possible to select a configuration of the motor selection and gear ratio such that the rated motor torque, multiplied by the gear ratio exceeds these ratings. It is the responsibility of the user to ensure that the settings of the system do not allow these values to be exceeded.

The right hand columns give the output torque at the indicated speed which will result in 10,000 hour life (L10). The setup of the system will determine the actual output torque and speed.

| Gearing Reflected Inertia |                         |                       |                   |                         |                       |
|---------------------------|-------------------------|-----------------------|-------------------|-------------------------|-----------------------|
| Single Reduction          |                         |                       | Double Reduction  |                         |                       |
| Gear Stages               | lbf-in-sec <sup>2</sup> | (kg-cm <sup>2</sup> ) | Gear Stages       | lbf-in-sec <sup>2</sup> | (kg-cm <sup>2</sup> ) |
| 4:1                       | 0.0000132               | (0.149)               | 16:1              | 0.0000121               | (0.0137)              |
| 5:1                       | 0.0000087               | (0.00984)             | 20:1, 25:1        | 0.0000080               | (0.00906)             |
| 10:1                      | 0.0000023               | (0.00261)             | 40:1, 50:1, 100:1 | 0.0000021               | (0.00242)             |

| Backlash and Efficiency     |                  |                  |
|-----------------------------|------------------|------------------|
|                             | Single Reduction | Double Reduction |
| Backlash at 1% Rated Torque | 10 Arc min       | 13 Arc min       |
| Efficiency                  | 91%              | 86%              |

| Motor and Gearmotor Weights |                      |                             |                             |                        |
|-----------------------------|----------------------|-----------------------------|-----------------------------|------------------------|
|                             | RDM060 without Gears | RDG060 with 1 Stage Gearing | RDG060 with 2 Stage Gearing | Added Weight for Brake |
| 1 Stack Stator lb (kg)      | 3.0 (1.4)            | 7.5 (3.4)                   | 9.3 (4.2)                   | 0.6 (0.3)              |
| 2 Stack Stator lb (kg)      | 4.1 (1.9)            | 8.6 (3.9)                   | 10.4 (4.7)                  |                        |
| 3 Stack Stator lb (kg)      | 5.2 (2.4)            | 9.7 (4.4)                   | 11.5 (5.2)                  |                        |



## RDM/G075

| Rotary Motor Torque and Speed Ratings    |  |             |             |           |
|--|--|-------------|-------------|-----------|
|  | Stator   | 1 Stack     | 2 Stack     | 3 Stack   |
|  | RPM at 48 VDC                                  | 4000        | 3000        | 2000      |
| Continuous Torque                        | lbf-in (Nm)                                    | 13 (1.46)   | 18.5 (2.09) | 29 (3.28) |
| Peak Torque                              | lbf-in (Nm)                                    | 18.9 (2.08) | 28 (3.16)   | 41 (4.63) |
| Drive Current @ Continuous Torque        | Amps   | 22          | 22          | 22        |
| Operating Temperature Range**            | -20 to 65° C (-40° C available, consult Exlar) |             |             |           |
| Maximum Continuous Power Supply Current† | Amps   | 15          | 18          | 18        |

\*Power supply current is based on software current limit, not thermal limit. Consideration for peak current should also be considered when sizing power supplies. For output torque of RDG gearmotors, multiply by ratio and efficiency. Please note maximum allowable output torques shown below.

\*\*Ratings based on 40° C ambient conditions.

| Inertia                                 |   |                      |                      |                      |
|---|---|----------------------|----------------------|----------------------|
|   | Stator  | 1 Stack              | 2 Stack              | 3 Stack              |
| RDM Motor Armature Inertia (+/-5%)      | lb-in-sec <sup>2</sup><br>(kg-cm <sup>2</sup> ) | 0.000545<br>(0.6158) | 0.000973<br>(1.0996) | 0.001401<br>(1.5834) |
| RDG Gearmotor Armature Inertia† (+/-5%) | lb-in-sec <sup>2</sup><br>(kg-cm <sup>2</sup> ) | 0.000660<br>(0.7450) | 0.001068<br>(1.2057) | 0.001494<br>(1.6868) |

\*Add armature inertia to gearing inertia for total inertia.

| L <sub>10</sub> Radial Load and Bearing Life |               |               |              |              |              |             |
|--|---------------|---------------|--------------|--------------|--------------|-------------|
| RPM  | 50            | 100           | 250          | 500          | 1000         | 3000        |
| RDM075<br>lbf (N)                            | 278<br>(1237) | 220<br>(979)  | 162<br>(721) | 129<br>(574) | 102<br>(454) | 71<br>(316) |
| RDG075<br>lbf (N)                            | 343<br>(1526) | 272<br>(1210) | 200<br>(890) | 159<br>(707) | 126<br>(560) | 88<br>(391) |

Side load ratings shown above are for 10,000 hour bearing life at 25 mm from motor face at given rpm.

| Gearmotor Mechanical Ratings |       |   |   |                      |                      |
|------------------------------|-------|---|---|----------------------|----------------------|
| Model                        | Ratio | Maximum Allowable Output Torque-Set by User lbf-in (Nm) | Output Torque at Motor Speed for 10,000 Hour Life |                      |                      |
|                              |       |   | 1000 RPM lbf-in (Nm)                              | 2500 RPM lbf-in (Nm) | 4000 RPM lbf-in (Nm) |
| RDG075-004                   | 4:1   | 1618 (182.8)  | 384 (43.4)  | 292 (32.9)           | 254 (28.7)           |
| RDG075-005                   | 5:1   | 1446 (163.4)  | 395 (44.6)  | 300 (33.9)           | 260 (29.4)           |
| RDG075-010                   | 10:1  | 700 (79.1)  | 449 (50.7)  | 341 (38.5)           | 296 (33.4)           |

Two torque ratings for the RDG gearmotors are given in the table above. The left hand columns give the maximum (peak) allowable output torque for the indicated ratios of each size RDG gearmotor. This is not the rated output torque of the motor multiplied by the ratio of the reducer.

It is possible to select a configuration of the motor selection and gear ratio such that the rated motor torque, multiplied by the gear ratio exceeds these ratings. It is the responsibility of the user to ensure that the settings of the system do not allow these values to be exceeded.

The right hand columns give the output torque at the indicated speed which will result in 10,000 hour life (L10). The setup of the system will determine the actual output torque and speed.

| Gearing Reflected Inertia |                         |                       |
|---------------------------|-------------------------|-----------------------|
| Single Reduction (+/-5%)  |                         |                       |
| Gear Stages               | lbf-in-sec <sup>2</sup> | (kg-cm <sup>2</sup> ) |
| 4:1                       | 0.000095                | (0.107)               |
| 5:1                       | 0.000062                | (0.069)               |
| 10:1                      | 0.000117                | (0.019)               |

| Backlash and Efficiency     |                  |
|-----------------------------|------------------|
|                             | Single Reduction |
| Backlash at 1% Rated Torque | 10 Arc min       |
| Efficiency                  | 91%              |

| Motor and Gearmotor Weights |         |                        |                             |
|-----------------------------|---------|------------------------|-----------------------------|
|                             |         | RDM075 without Gears   | RDG075 with 1 Stage Gearing |
| 1 Stack Stator              | lb (kg) | 7.4 (3.4)              | 9.8 (4.4)                   |
| 2 Stack Stator              | lb (kg) | 9.2 (4.2)              | 11.6 (5.3)                  |
| 3 Stack Stator              | lb (kg) | 11 (4.9)               | 13.4 (6.1)                  |
|                             |         | Added Weight for Brake |                             |
|                             |         | 1.0 (0.5)              |                             |

## RDM/G090

| Rotary Motor Torque and Speed Ratings    |  |             |           |             |
|--|--|-------------|-----------|-------------|
|  | Stator   | 1 Stack     | 2 Stack   | 3 Stack     |
|  | RPM at 48 VDC                                  | 3300        | 1800      | 1400        |
| Continuous Torque                        | lbf-in (Nm)                                    | 17 (1.92)   | 28 (3.16) | 41 (4.63)   |
| Peak Torque                              | lbf-in (Nm)                                    | 21.8 (2.46) | 36 (4.07) | 52.8 (5.97) |
| Drive Current @ Continuous Torque        | Amps   | 22          | 22        | 22          |
| Operating Temperature Range**            | -20 to 65° C (-40° C available, consult Exlar) |             |           |             |
| Maximum Continuous Power Supply Current† | Amps   | 18          | 18        | 18          |

\*Power supply current is based on software current limit, not thermal limit. Consideration for peak current should also be considered when sizing power supplies. For output torque of RDG gearmotors, multiply by ratio and efficiency. Please note maximum allowable output torques shown below.

\*\*Ratings based on 40° C ambient conditions.

| Inertia                                 |   |                    |                   |                   |
|---|---|--------------------|-------------------|-------------------|
|   | Stator  | 1 Stack            | 2 Stack           | 3 Stack           |
| RDM Motor Armature Inertia (+/-5%)      | lb-in-sec <sup>2</sup><br>(kg-cm <sup>2</sup> ) | 0.00054<br>(0.609) | 0.00097<br>(1.09) | 0.00140<br>(1.58) |
| RDG Gearmotor Armature Inertia* (+/-5%) | lb-in-sec <sup>2</sup><br>(kg-cm <sup>2</sup> ) | 0.00114<br>(1.29)  | 0.00157<br>(1.77) | 0.00200<br>(2.26) |

\*Add armature inertia to gearing inertia for total inertia.

| L <sub>10</sub> Radial Load and Bearing Life |               |               |               |              |              |              |
|--|---------------|---------------|---------------|--------------|--------------|--------------|
| RPM  | 50            | 100           | 250           | 500          | 1000         | 3000         |
| RDM090<br>lbf (N)                            | 427<br>(1899) | 340<br>(1512) | 250<br>(1112) | 198<br>(881) | 158<br>(703) | 109<br>(485) |
| RDG090<br>lbf (N)                            | 350<br>(1557) | 278<br>(1237) | 205<br>(912)  | 163<br>(725) | 129<br>(574) | 89<br>(396)  |

Side load ratings shown above are for 10,000 hour bearing life at 25 mm from motor face at given rpm.

| Gearmotor Mechanical Ratings |       |   |   |                      |                      |
|------------------------------|-------|---|---|----------------------|----------------------|
| Model                        | Ratio | Maximum Allowable Output Torque-Set by User lbf-in (Nm) | Output Torque at Motor Speed for 10,000 Hour Life |                      |                      |
|                              |       |   | 1000 RPM lbf-in (Nm)                              | 2500 RPM lbf-in (Nm) | 3300 RPM lbf-in (Nm) |
| RDG090-004                   | 4:1   | 2078 (234.8)  | 698 (78.9)  | 530 (59.9)           | 488 (55.1)           |
| RDG090-005                   | 5:1   | 1798 (203.1)  | 896 (101.2)                                       | 680 (76.8)           | 626 (70.7)           |
| RDG090-010                   | 10:1  | 1126 (127.2)  | 1043 (117.8)                                      | 792 (89.5)           | 729 (82.4)           |
| RDG090-016                   | 16:1  | 2078 (234.8)  | 1057 (119.4)                                      | 803 (90.7)           | 739 (83.5)           |
| RDG090-020                   | 20:1  | 2078 (234.8)  | 1131 (127.8)                                      | 859 (97.1)           | 790 (89.3)           |
| RDG090-025                   | 25:1  | 1798 (203.1)  | 1452 (164.1)                                      | 1103 (124.6)         | 1015 (114.7)         |
| RDG090-040                   | 40:1  | 2078 (234.8)  | 1392 (157.3)                                      | 1057 (119.4)         | 973 (109.9)          |
| RDG090-050                   | 50:1  | 1798 (203.1)  | 1787 (201.9)                                      | 1358 (153.4)         | 1249 (141.1)         |
| RDG090-100                   | 100:1 | 1126 (127.2)  | 1100 (124.3)                                      | 1100 (124.3)         | 1100 (124.3)         |

Two torque ratings for the RDG gearmotors are given in the table above. The left hand columns give the maximum (peak) allowable output torque for the indicated ratios of each size RDG gearmotor. This is not the rated output torque of the motor multiplied by the ratio of the reducer.

It is possible to select a configuration of the motor selection and gear ratio such that the rated motor torque, multiplied by the gear ratio exceeds these ratings. It is the responsibility of the user to ensure that the settings of the system do not allow these values to be exceeded.

The right hand columns give the output torque at the indicated speed which will result in 10,000 hour life (L10). The setup of the system will determine the actual output torque and speed.

| Gearing Reflected Inertia |                         |                       |                   |                         |                       |
|---------------------------|-------------------------|-----------------------|-------------------|-------------------------|-----------------------|
| Gear Stages               | Single Reduction        |                       | Double Reduction  |                         |                       |
|                           | lbf-in-sec <sup>2</sup> | (kg-cm <sup>2</sup> ) | Gear Stages       | lbf-in-sec <sup>2</sup> | (kg-cm <sup>2</sup> ) |
| 4:1                       | 0.0000154               | (0.174)               | 16:1              | 0.000115                | (0.130)               |
| 5:1                       | 0.0000100               | (0.113)               | 20:1, 25:1        | 0.0000756               | (0.0854)              |
| 10:1                      | 0.0000265               | (0.0300)              | 40:1, 50:1, 100:1 | 0.0000203               | (0.0230)              |

| Backlash and Efficiency     |                  |                  |
|-----------------------------|------------------|------------------|
|                             | Single Reduction | Double Reduction |
| Backlash at 1% Rated Torque | 10 Arc min       | 13 Arc min       |
| Efficiency                  | 91%              | 86%              |

| Motor and Gearmotor Weights |                      |                             |                             |                        |
|-----------------------------|----------------------|-----------------------------|-----------------------------|------------------------|
|                             | RDM090 without Gears | RDG090 with 1 Stage Gearing | RDG090 with 2 Stage Gearing | Added Weight for Brake |
| 1 Stack Stator lb (kg)      | 12.5 (5.7)           | 20.5 (9.3)                  | 23.5 (10.7)                 | 1.5 (0.7)              |
| 2 Stack Stator lb (kg)      | 15.5 (7.0)           | 23.5 (10.7)                 | 26.5 (12)                   |                        |
| 3 Stack Stator lb (kg)      | 18.5 (8.4)           | 26.5 (12.0)                 | 29.5 (13.4)                 |                        |

## Speed vs. Torque Curves

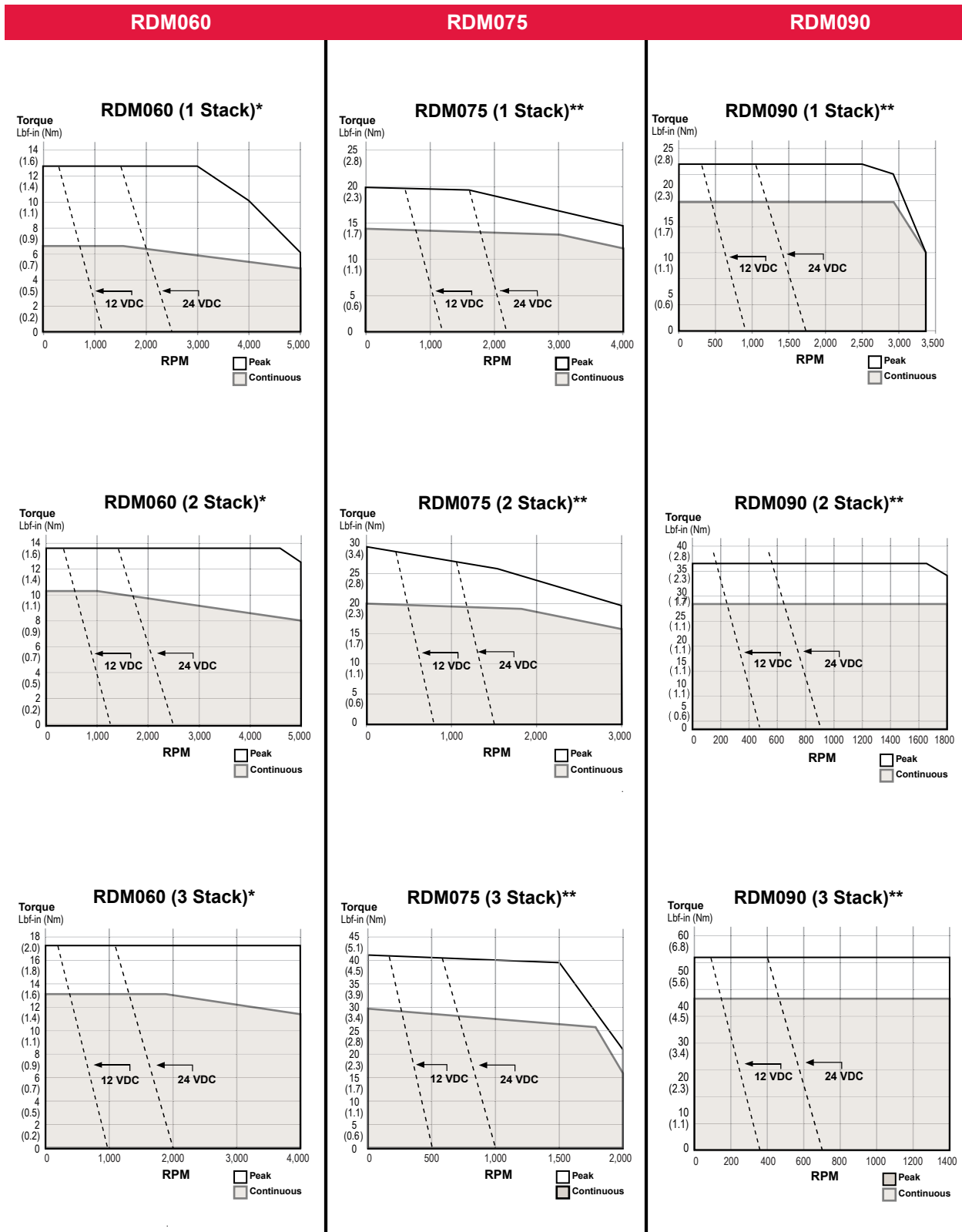

For RDG gearmotors, multiply torque by ratio and efficiency. Divide speed by gear ratio.

\* RDM060 test data derived using NEMA recommended aluminum heatsink 10" x 10" x 1/4" at 40°C ambient

\*\*RDM075 and RDM090 test data derived using NEMA recommended aluminum heatsink 10" x 10" x 3/8" at 40°C ambient

## Dimensions

### RDM/G060 Base Actuator

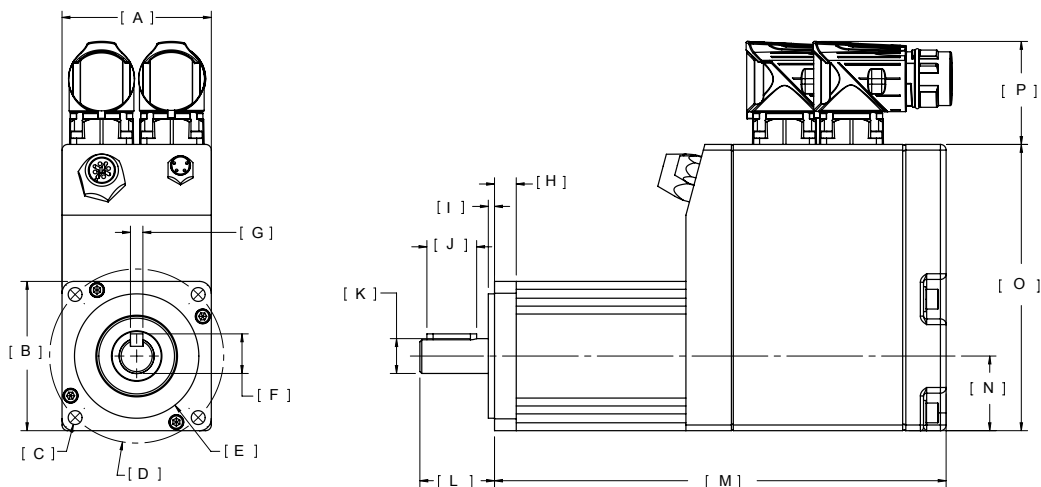

|          |    | RDM060            | RDG060            |          |    | RDM060            | RDG060            |
|----------|----|-------------------|-------------------|----------|----|-------------------|-------------------|
| <b>A</b> | in | 2.36              | 2.36              | <b>I</b> | in | 0.10              | 0.12              |
|          | mm | 60                | 60                |          | mm | 2.5               | 3.0               |
| <b>B</b> | in | 2.36              | 2.36              | <b>J</b> | in | 0.79              | 0.98              |
|          | mm | 60                | 60                |          | mm | 20.0              | 25.0              |
| <b>C</b> | in | 4X Ø 0.22         | 4X Ø 0.22         | <b>K</b> | in | Ø 0.5512 / 0.5507 | Ø 0.6302 / 0.6298 |
|          | mm | 5.6               | 5.6               |          | mm | 14 h6             | 16 j6             |
| <b>D</b> | in | Ø 2.75 BC         | Ø 2.75 BC         | <b>L</b> | in | 1.18              | 1.43              |
|          | mm | 70.0              | 70.0              |          | mm | 30.0              | 36.3              |
| <b>E</b> | in | Ø 1.9681 / 1.9675 | Ø 1.9681 / 1.9675 | <b>M</b> | in | See Below         | See Below         |
|          | mm | 50 g6             | 50 g6             |          | mm | See Below         | See Below         |
| <b>F</b> | in | 0.63              | 0.70              | <b>N</b> | in | 1.18              | 1.18              |
|          | mm | 15.9              | 17.9              |          | mm | 30.0              | 30.0              |
| <b>G</b> | in | Ø 0.1969 / 0.1957 | Ø 0.1969 / 0.1957 | <b>O</b> | in | 4.53              | 4.53              |
|          | mm | 5 h9              | 5 h9              |          | mm | 115.1             | 115.1             |
| <b>H</b> | in | 0.34              | 0.38              | <b>P</b> | in | 1.63              | 1.63              |
|          | mm | 8.7               | 9.7               |          | mm | 41.4              | 41.4              |

### RDM060

| Without Brake Option |                |                |                |
|----------------------|----------------|----------------|----------------|
| DIM                  | 1 Stack Stator | 2 Stack Stator | 3 Stack Stator |
| M                    | 7.146 (185.1)  | 8.396 (213.3)  | 9.646 (245.0)  |

| With Brake Option |                |                |                |
|-------------------|----------------|----------------|----------------|
| DIM               | 1 Stack Stator | 2 Stack Stator | 3 Stack Stator |
| M                 | 7.856 (199.5)  | 9.106 (231.3)  | 10.356 (263.0) |

### RDG060

| Without Brake Option |                                    |                                    |                                    |
|----------------------|------------------------------------|------------------------------------|------------------------------------|
| DIM                  | 1 Stack Stator<br>1 Stage Gearhead | 2 Stack Stator<br>1 Stage Gearhead | 3 Stack Stator<br>1 Stage Gearhead |
| M                    | 9.434 (240)                        | 10.684 (271)                       | 11.934 (303)                       |
| DIM                  | 1 Stack Stator<br>2 Stage Gearhead | 2 Stack Stator<br>2 Stage Gearhead | 3 Stack Stator<br>2 Stage Gearhead |
| M                    | 10.479 (266)                       | 11.729 (298)                       | 12.979 (330)                       |

| With Brake Option |                                    |                                    |                                    |
|-------------------|------------------------------------|------------------------------------|------------------------------------|
| DIM               | 1 Stack Stator<br>1 Stage Gearhead | 2 Stack Stator<br>1 Stage Gearhead | 3 Stack Stator<br>1 Stage Gearhead |
| M                 | 10.144 (258)                       | 11.394 (289)                       | 12.644 (321)                       |
| DIM               | 1 Stack Stator<br>2 Stage Gearhead | 2 Stack Stator<br>2 Stage Gearhead | 3 Stack Stator<br>2 Stage Gearhead |
| M                 | 11.189 (284)                       | 12.439 (316)                       | 13.689 (348)                       |

Pre-sale drawings and models are representative and are subject to change. Certified drawings and models are available for a fee. Consult your local Exlar representative for details.

## RDM/G075 Base Actuator

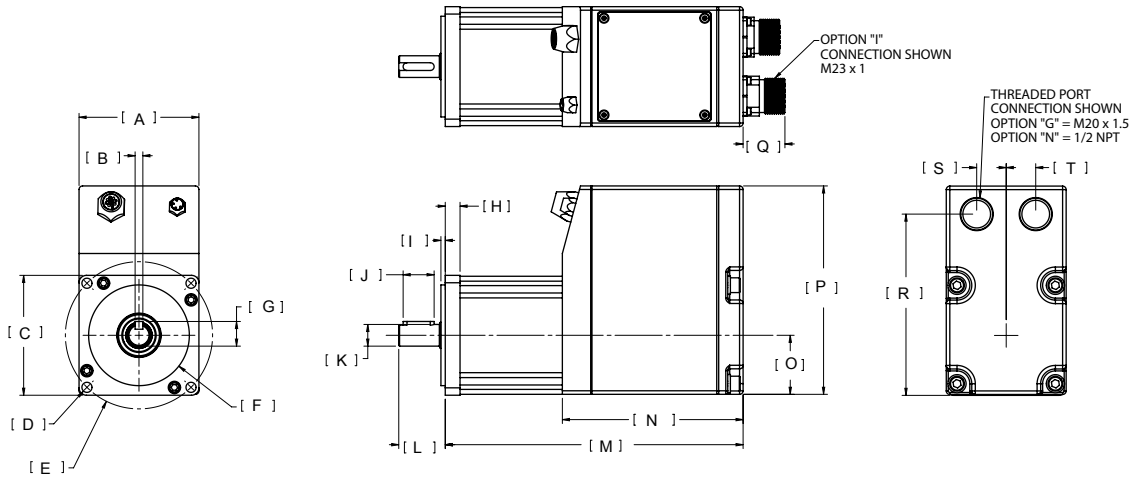

|          |    | RDM075            | RDG075            |          |    | RDM075            | RDG075            |
|----------|----|-------------------|-------------------|----------|----|-------------------|-------------------|
| <b>A</b> | in | 3.05              | 3.05              | <b>K</b> | in | Ø 0.5512 / 0.5508 | Ø 0.6302 / 0.6298 |
|          | mm | 77.4              | 77.4              |          | mm | 14 h6             | 16 j6             |
| <b>B</b> | in | Ø 0.1969 / 0.1957 | Ø 0.1969 / 0.1957 | <b>L</b> | in | 1.18              | 1.18              |
|          | mm | 5 h9              | 5 h9              |          | mm | 30.0              | 30.0              |
| <b>C</b> | in | □ 3.05            | □ 3.05            | <b>M</b> | in | See Below         | See Below         |
|          | mm | 77.4              | 77.4              |          | mm | See Below         | See Below         |
| <b>D</b> | in | 4X Ø 0.26 ON BC   | 4X Ø 0.26 ON BC   | <b>N</b> | in | 4.59              | 4.59              |
|          | mm | 6.5               | 6.5               |          | mm | 116.6             | 116.6             |
| <b>E</b> | in | Ø 3.74 BC         | Ø 3.74 BC         | <b>O</b> | in | 1.5               | 1.5               |
|          | mm | 95.0              | 95.0              |          | mm | 38.1              | 38.1              |
| <b>F</b> | in | Ø 2.5587 / 2.5580 | Ø 2.5587 / 2.5580 | <b>P</b> | in | 5.30              | 5.30              |
|          | mm | 65 g6             | 65 g6             |          | mm | 134.5             | 134.5             |
| <b>G</b> | in | 0.63              | 0.70              | <b>Q</b> | in | 1.06              | 1.06              |
|          | mm | 15.9              | 17.9              |          | mm | 27.0              | 27.0              |
| <b>H</b> | in | 0.38              | 0.45              | <b>R</b> | in | 4.61              | 4.61              |
|          | mm | 9.5               | 11.5              |          | mm | 117.0             | 117.0             |
| <b>I</b> | in | 0.11              | 0.11              | <b>S</b> | in | 0.75              | 0.75              |
|          | mm | 2.8               | 2.8               |          | mm | 19.1              | 19.1              |
| <b>J</b> | in | 0.79              | 0.79              | <b>T</b> | in | 0.75              | 0.75              |
|          | mm | 20.0              | 20.0              |          | mm | 19.1              | 19.1              |

### RDM075

| Without Brake Option |                |                |                |
|----------------------|----------------|----------------|----------------|
| DIM                  | 1 Stack Stator | 2 Stack Stator | 3 Stack Stator |
| M                    | 7.57 (192.3)   | 8.57 (217.7)   | 9.57 (243.1)   |

| With Brake Option |                |                |                |
|-------------------|----------------|----------------|----------------|
| DIM               | 1 Stack Stator | 2 Stack Stator | 3 Stack Stator |
| M                 | 8.85 (224.8)   | 9.85 (250.2)   | 10.85 (275.6)  |

### RDG075

| Without Brake Option |                                    |                                    |                                    |
|----------------------|------------------------------------|------------------------------------|------------------------------------|
| DIM                  | 1 Stack Stator<br>1 Stage Gearhead | 2 Stack Stator<br>1 Stage Gearhead | 3 Stack Stator<br>1 Stage Gearhead |
| M                    | 9.19 (233.4)                       | 10.19 (258.8)                      | 11.19 (284.2)                      |

| With Brake Option |                                    |                                    |                                    |
|-------------------|------------------------------------|------------------------------------|------------------------------------|
| DIM               | 1 Stack Stator<br>1 Stage Gearhead | 2 Stack Stator<br>1 Stage Gearhead | 3 Stack Stator<br>1 Stage Gearhead |
| M                 | 10.42 (264.7)                      | 11.42 (290.1)                      | 12.42 (315.5)                      |

Pre-sale drawings and models are representative and are subject to change. Certified drawings and models are available for a fee. Consult your local Exlar representative for details.

## RDM/G090 Base Actuator

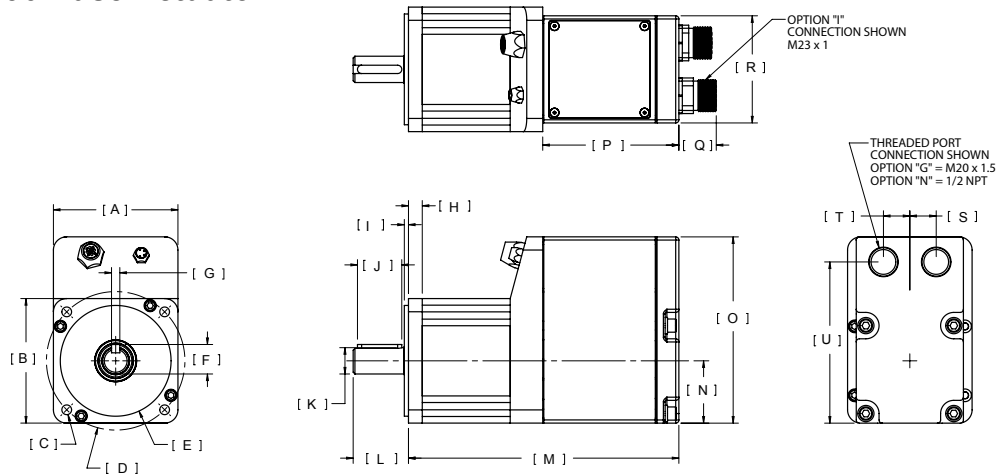

|          |    | RDM90             | RDG090            |          |    | RDM090    | RDG090    |
|----------|----|-------------------|-------------------|----------|----|-----------|-----------|
| <b>A</b> | in | 3.54              | 3.54              | <b>L</b> | in | 1.57      | 1.89      |
|          | mm | 90                | 90                |          | mm | 39.6      | 48.0      |
| <b>B</b> | in | 3.54              | 3.54              | <b>M</b> | in | See Below | See Below |
|          | mm | 90                | 90                |          | mm | See Below | See Below |
| <b>C</b> | in | 4X Ø 0.28         | 4X Ø 0.26         | <b>N</b> | in | 1.77      | 1.77      |
|          | mm | 7.0               | 6.5               |          | mm | 45.0      | 45.0      |
| <b>D</b> | in | Ø 3.94 BC         | Ø 3.94 BC         | <b>O</b> | in | 5.30      | 5.30      |
|          | mm | 100.0             | 100.0             |          | mm | 134.5     | 134.5     |
| <b>E</b> | in | Ø 3.1492 / 3.1485 | Ø 3.1492 / 3.1485 | <b>P</b> | in | 3.87      | 3.87      |
|          | mm | 80 g6             | 80 g6             |          | mm | 98.3      | 98.3      |
| <b>F</b> | in | 0.85              | 0.96              | <b>Q</b> | in | 1.06      | 1.06      |
|          | mm | 21.5              | 24.3              |          | mm | 27.0      | 27.0      |
| <b>G</b> | in | Ø 0.2362 / 0.2350 | Ø 0.2362 / 0.2350 | <b>R</b> | in | 3.05      | 3.05      |
|          | mm | 6 h9              | 6 h9              |          | mm | 77.4      | 77.4      |
| <b>H</b> | in | 0.39              | 0.63              | <b>S</b> | in | 0.75      | 0.75      |
|          | mm | 10.0              | 15.9              |          | mm | 19.1      | 19.1      |
| <b>I</b> | in | 0.12              | 0.12              | <b>T</b> | in | 0.75      | 0.75      |
|          | mm | 3.0               | 3.0               |          | mm | 19.1      | 19.1      |
| <b>J</b> | in | 1.26              | 1.42              | <b>U</b> | in | 4.58      | 4.58      |
|          | mm | 32.0              | 36.0              |          | mm | 116.4     | 116.4     |
| <b>K</b> | in | Ø 0.7480 / 0.7475 | Ø 0.8665 / 0.8659 |          |    |           |           |
|          | mm | 19 h6             | 22 j6             |          |    |           |           |

## RDM090

| Without Brake Option |                |                |                |
|----------------------|----------------|----------------|----------------|
| DIM                  | 1 Stack Stator | 2 Stack Stator | 3 Stack Stator |
| M                    | 7.69 (195.3)   | 8.69 (220.7)   | 9.69 (246.1)   |

| With Brake Option |                |                |                |
|-------------------|----------------|----------------|----------------|
| DIM               | 1 Stack Stator | 2 Stack Stator | 3 Stack Stator |
| M                 | 9.0 (228.6)    | 10.00 (254.0)  | 11.00 (279.4)  |

## RDG090

| Without Brake Option |                                    |                                    |                                    |
|----------------------|------------------------------------|------------------------------------|------------------------------------|
| DIM                  | 1 Stack Stator<br>1 Stage Gearhead | 2 Stack Stator<br>1 Stage Gearhead | 3 Stack Stator<br>1 Stage Gearhead |
| M                    | 10.80 (274.3)                      | 11.80 (299.7)                      | 12.80 (325.1)                      |
| DIM                  | 1 Stack Stator<br>2 Stage Gearhead | 2 Stack Stator<br>2 Stage Gearhead | 3 Stack Stator<br>2 Stage Gearhead |
| M                    | 12.06 (306.3)                      | 13.06 (331.7)                      | 14.06 (357.1)                      |

| With Brake Option |                                    |                                    |                                    |
|-------------------|------------------------------------|------------------------------------|------------------------------------|
| DIM               | 1 Stack Stator<br>1 Stage Gearhead | 2 Stack Stator<br>1 Stage Gearhead | 3 Stack Stator<br>1 Stage Gearhead |
| M                 | 12.13 (308.1)                      | 13.11 (333.0)                      | 14.11 (358.4)                      |
| DIM               | 1 Stack Stator<br>2 Stage Gearhead | 2 Stack Stator<br>2 Stage Gearhead | 3 Stack Stator<br>2 Stage Gearhead |
| M                 | 13.37 (339.6)                      | 14.37 (365.0)                      | 15.37 (390.4)                      |

Pre-sale drawings and models are representative and are subject to change. Certified drawings and models are available for a fee. Consult your local Exlar representative for details.

# Tritex II DC Linear Ordering Guide

[Return to Table of Contents](#)

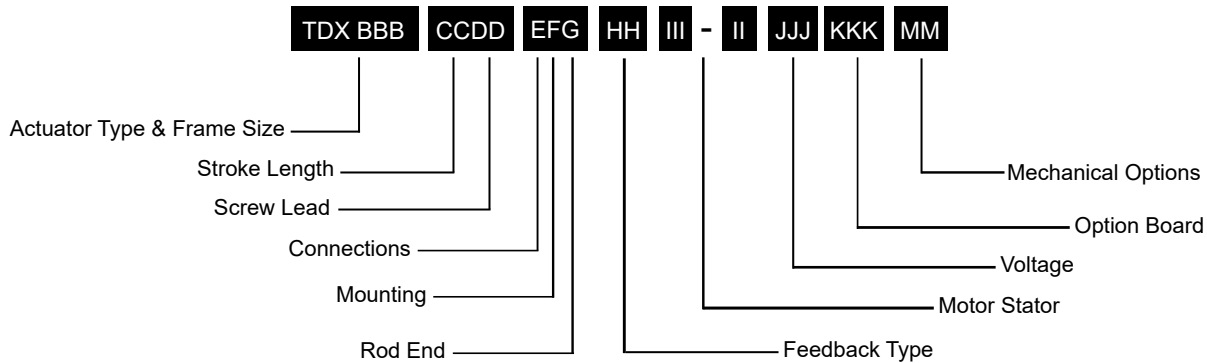

## Actuator Type

TDX = Tritex II Linear Actuator, high mechanical capacity

## BBB = Actuator Frame Size

060 = 60 mm  
075 = 75 mm

## CC = Stroke Length

03 = 3 inch (76 mm)  
06 = 6 inch (152 mm)  
10 = 10 inch (254 mm)  
12 = 12 inch (305 mm)  
18 = 18 inch (457 mm) (75 mm only)

## DD = Screw Lead (linear travel per screw revolution)

01 = 0.1 inch (2.54 mm)  
02 = 0.2 inch (5.08 mm)  
04 = 0.4 inch (10.16 mm) (60 mm only)  
05 = 0.5 inch (12.7 mm) (75 mm only)

## E = Connections

G = Standard Straight Threaded Port with internal terminals, M20x1.5 (75 mm only)  
N = NPT Threaded Port via Adapter with Internal Terminals, 1/2" NPT (75 mm only)  
I = Intercontec Style - Exlar standard, M23 Style Connector

## F = Mounting

C = Rear Clevis  
G = Metric Rear Clevis  
D = Double Side Mount  
K = Metric Double Side Mount  
E = Extended Tie Rod  
M = Metric Extended Tie Rod  
F = Front Flange  
R = Rear Flange  
T = Side Trunnion  
Q = Metric Side Trunnion

## G = Rod End

M = Male US Standard Thread <sup>1</sup>  
A = Male Metric Thread <sup>1</sup>  
F = Female US Standard Thread <sup>1</sup>  
B = Female Metric Thread <sup>1</sup>

## HH = Feedback Type

HD = Analog Hall Device  
IE = Incremental Encoder, 8192 count resolution  
AF = Absolute Feedback <sup>9</sup>

## III-II = Motor Stator, All 8 Pole

TDX060 Stator Specifications  
1B8-50 = 1 Stack, 48 VDC, 5000 rpm  
2B8-50 = 2 Stack, 48 VDC, 5000 rpm  
3B8-40 = 3 Stack, 48 VDC, 4000 rpm <sup>2</sup>

## TDX075 Stator Specifications

1B8-30 = 1 Stack, 48 VDC, 3000 rpm  
2B8-30 = 2 Stack, 48 VDC, 3000 rpm  
3B8-20 = 3 Stack, 48 VDC, 2000 rpm <sup>2</sup>

## JJJ = Voltage

048 = 12-48 VDC

## KKK = Option Board

SIO = Standard IO Interconnect  
IA4 = 4-20 mA Analog I/O  
EIP = SIO plus Ethernet/IP with M12 connector  
EIN = SIO plus Ethernet/IP without M12 connector <sup>7</sup>  
PIO = SIO plus Profinet IO with M12 connector <sup>7</sup>  
PIN = SIO plus Profinet IO without M12 connector <sup>7</sup>  
TCP = SIO plus Modbus TCP with M12 connector  
TCN = SIO plus Modbus TCP without M12 connector <sup>9</sup>

## MM = Mechanical Options <sup>3</sup>

AR = External Anti-rotate  
L1/2/3 = External Limit Switches <sup>4</sup>  
RB = Rear Brake  
PB = Protective Bellows <sup>6</sup>  
SR = Splined Main Rod <sup>5,8</sup>



For options or specials not listed above or for extended temperature operation, please contact Exlar

## NOTES:

1. Chrome-plated carbon steel. Threads not chrome-plated.
2. Not available on 0.1 inch lead.
3. For extended temperature operation consult factory for model number.
4. Limit switch option requires AR option.
5. This option is not sealed and is not suitable for any environment in which contaminants come in contact with actuator and may enter the actuator.
6. Not available with extended tie rod mounting option.
7. Requires customer supplied Ethernet cable through I/O port for Class 1 Division 2 compliance only.
8. Consult Exlar if ordering splined stainless steel main rod.
9. When ordering a TDM, RDM or RDG 60 mm or other sizes with top mounted connectors the battery backup for AF feedback must be mounted externally. A DIN rail mounted board (Exlar PN 48224) and battery (PN T2BAT2) are supplied.

# Tritex II DC Rotary Ordering Guide

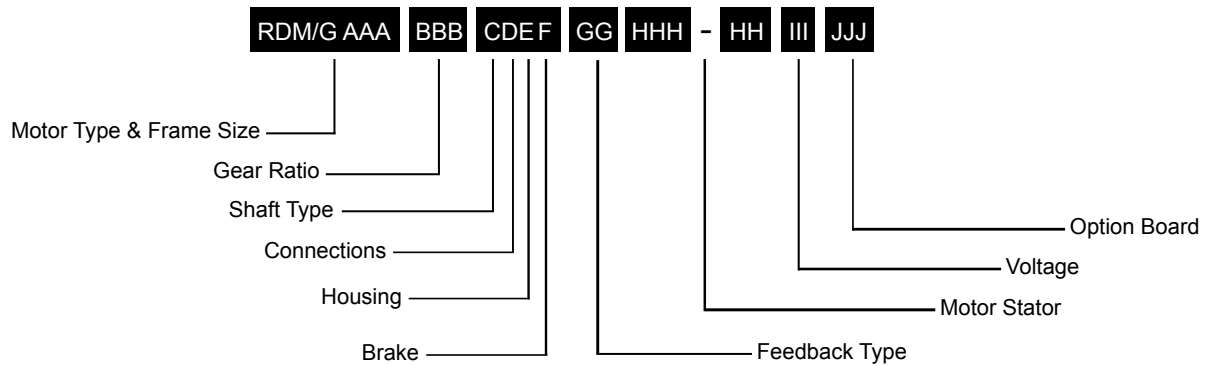

## RDM/G = Motor Type

RDM = Tritex II DC Rotary Motor  
RDG = Tritex II DC Rotary Gearmotor

## AAA = Frame Size

060 = 60 mm  
075 = 75 mm  
090 = 90 mm

## BBB = Gear Ratio

Blank = RDM  
Single Reduction Ratios  
004 = 4:1 005 = 5:1 010 = 10:1  
Double Reduction Ratios (NA on 75 mm)  
016 = 16:1 020 = 20:1  
025 = 25:1 040 = 40:1  
050 = 50:1 100 = 100:1

## C = Shaft Type

K = Keyed

## D = Connections

G = Standard straight threaded port with internal terminals, M20x1.5 (75 & 90 mm only)  
N = NPT threaded port internal terminals, 1/2" NPT (75 & 90 mm only)  
I = Intercontec style – Exlar standard, M23 Style Connector

## E = Housing Options

G = Exlar Standard

## F = Brake Options

S = No Brake, Standard  
B = Electric Brake, 24 VDC

## GG = Feedback Type

HD = Analog Hall Device  
IE = Incremental Encoder, 8192 Count Resolution  
AF = Absolute Feedback<sup>3</sup>

## HHH-HH = Motor Stators - All 8 Pole

RDM/G060 Stator Specifications  
1B8-50 = 1 Stack, 48 VDC, 5000 rpm  
2B8-50 = 2 Stack, 48 VDC, 5000 rpm  
3B8-40 = 3 Stack, 48 VDC, 4000 rpm

## RDM/G075 Stator Specifications

1B8-40 = 1 Stack, 48 VDC, 4000 rpm  
2B8-30 = 2 Stack, 48 VDC, 3000 rpm  
3B8-20 = 3 Stack, 48 VDC, 2000 rpm

## RDM/G090 Stator Specifications

1B8-33 = 1 Stack, 48 VDC, 3300 rpm  
2B8-18 = 2 Stack, 48 VDC, 1800 rpm  
3B8-14 = 3 Stack, 48 VDC, 1400 rpm

## III = Voltage

048 = 12-48 VDC

## JJJ = Option Board

SIO = Standard I/O Interconnect  
IA4 = + 4-20 mA Analog I/O  
EIP = SIO plus EtherNet/IP with M12 connector  
EIN = SIO plus EtherNet/IP without M12 connector<sup>2</sup>  
PIO = SIO plus Profinet IO w/M12 connector  
PIN = SIO plus Profinet IO without M12 connector<sup>2</sup>  
TCP = SIO plus Modbus TCP w/M12 connector  
TCN = SIO plus Modbus TCP without M12 connector<sup>2</sup>



For options or specials not listed above or for extended temperature operation, please contact Exlar

## NOTES:

1. For extended temperature operation consult factory for model number.
2. Requires customer supplied Ethernet cable through I/O port for Class 1 Division 2 compliance only. Also N/A on 60 mm.
3. When ordering a TDM, RDM or RDG 60 mm or other sizes with top mounted connectors the battery backup for AF feedback must be mounted externally. A DIN rail mounted board (Exlar PN 48224) and battery (PN T2BAT2) are supplied.



# Tritex II DC Ordering Guide

## Cables and Accessories

| Tritex II DC Series Cable & Accessories  | Part No.            |
|--|---------------------|
| <b>Communications Accessories - Tritex uses a 4 pin M8 RS485 communications connector</b>                                  |                     |
| Recommended PC to Tritex communications cable-USB/RS485 to M8 connector - xxx = Length in feet, 006 or 015 only            | CBL-T2USB485-M8-xxx |
| <b>Multi-Drop RS485 Accessories</b>  |                     |
| RS485 splitter - M8 Pin plug to double M8 Socket receptacle  | TT485SP             |
| Multidrop Communications Cable M8 to M8 for use with TT485SP/RS485 splitter - xxx = Length in feet, 006 or 015 only        | CBL-TTDAS-xxx       |
| <b>“G” Connection Accessories (N/A for 60 mm)</b>  |                     |
| Nickel plated cable gland- M20 x 1.5 - CE shielding- 2 required  | GLD-T2M20 x 1.5     |
| Power cable prepared on one end for use with GLD-T2M20 x 1.5 xxx = Length in ft, Standard lengths 015, 025, 050, 075, 100  | CBL-TDIPC-RAW-xxx   |
| I/O cable prepared on one end for use with GLD-T2M20 x 1.5 xxx = Length in ft, Standard lengths 015, 025, 050, 075, 100    | CBL-T2IOC-RAW-xxx   |
| <b>“N” Connection Accessories (N/A for 60 mm)</b>  |                     |
| M20 x 1.5 to 1/2" NPT threaded hole adapter for use with conduit   | ADAPT-M20-NPT1/2    |
| <b>“I” Connection</b>  |                     |
| Power cable with M23 8 pin xxx = Length in feet, std lengths 015, 025, 050, 075, 100                                       | CBL-TTIPC-SMI-xxx   |
| I/O cable with M23 19 pin xxx = Length in feet, std lengths 015, 025, 050, 075, 100  | CBL-TTIOC-SMI-xxx   |
| <b>Multi-Purpose Communications Accessories for long runs, requires terminal block interconnections</b>                    |                     |
| USB to RS485 convertor/cable - USB to RS485 flying leads - xxx = Length in feet, 006 or 015 only                           | CBL-T2USB485-xxx    |
| Communications cable M8 to flying leads cable xxx = Length in feet, standard lengths 015, 025, 050, 075, 100               | CBL-TTCOM-xxx       |
| <b>Option Board Cables and Accessories</b>   |                     |
| EIP, PIO and TCP option Ethernet cable - M12 to RJ45 cable xxx = Length in feet, standard lengths 015, 025, 050, 075, 100. | CBL-T2ETH-R45-xxx   |
| <b>Electrical Accessories</b>  |                     |
| 48VDC, 10Amp Unregulated Power Supply  | TTPS1048            |
| 48VDC, 15Amp Unregulated Power Supply  | TTPS1548            |
| Shunt resistor used for Dynamic Braking  | TTSR1               |
| Replacement -AF Battery - 75 mm frame only used for absolute feedback option   | 54108               |
| Replacement -External Battery, Absolute Feedback option only (60mm frame)  | T2BAT2              |
| Replacement -AF Battery Board, T2BAT2 not included, DIN Rail mounted, Absolute Feedback option only (60mm frame)           | 48224               |
| Surge Filter DIN rail mounted  | TDCEFS1             |
| Replacement Normally Closed External Limit Switch (Turck Part No. BIM-UNT-RP6X)  | 43404               |
| Replacement Normally Open External Limit Switch (Turck Part No. BIM-UNT-AP6X)  | 43403               |
| <b>Mechanical Accessories</b>  |                     |
| Clevis Pin for TDX060 Rod Clevis & Rear Clevis   | CP050*              |
| Clevis Pin for TDX075 Rear Clevis  | CP075               |
| Spherical Rod Eye for TDX060 male “M” rod end 3/8-24 thread  | SRM038              |
| Spherical Rod Eye for TDX075 male “M” rod end 7/16-20 thread   | SRM044              |
| Rod Eye for TDX075 male “M” rod end 7/16-20 thread   | RE050               |
| Rod Clevis for TDX060 male “M” rod end 3/8-24 thread   | RC038               |
| Rod Clevis for TDX075 male “M” rod end 7/16-20 thread  | RC050               |
| Jam Nut for TDX060 male rod end, 3/8-24  | JAM3/8-24-SS        |
| Jam Nut for TDX075 male rod end, 7/16-20   | JAM7/16-20-SS       |

\*Also available for TDX075 with RC050, RE050



**CBL-T2USB485-M8-xxx**  
Our recommended communications cable. No special drivers or setup required for use with MS Windows™.



**CBL-T2USB485-xxx**  
Use for terminal connections with CBL-TTCOM for long cable runs. No special drivers or setup required for use with MS Windows™.



**CBL-TTIOC-SMI-xxx**



**CBL-TTIPC-SMI-xxx**



**CBL-TTCOM-xxx**  
Use with CBL-T2USB485-xxx for long cable runs.



**CBL-TTDAS-xxx**  
For use with TT485SP for multi-drop applications.



**TT485SP**  
RS485 communications splitter. Use to daisy-chain multiple Tritex actuators.

## **TDCESF1**

Surge filter designed for use on Tritex 48 VDC rotary and linear actuators provides EFT/B and surge disturbance immunity to IEC/EN 61800-3:2004-08 Second Environment (industrial) levels. Electrical Fast Transient/Burst (EET/B) and surge disturbances are caused by a number of events including switching inductive loads, relay contact bounce, power system switching activity or faults, nearby lightning strikes, etc.