

**CURTISS -
WRIGHT**

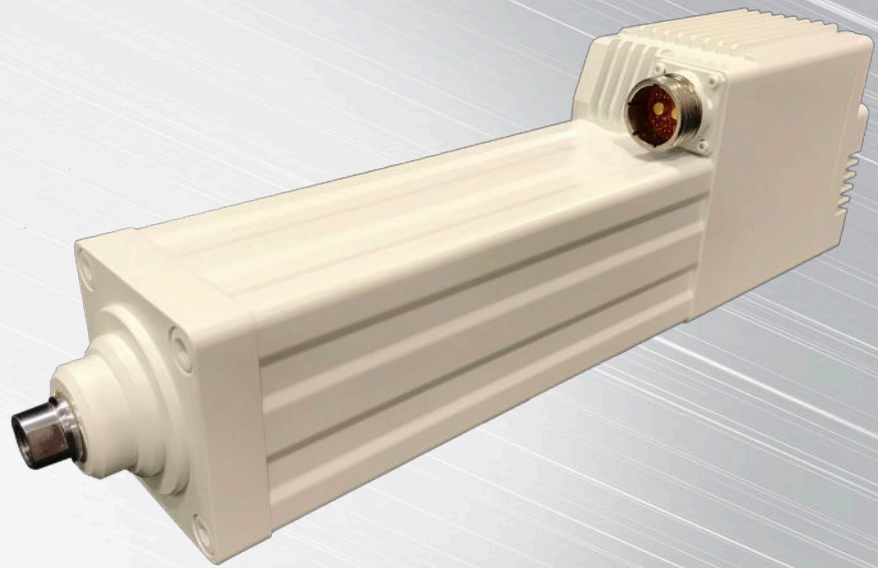

SA Series
Intelligent Electromechanical Actuator

Smart Actuator Product Brochure

EXLAR[®]

SA Series Smart Actuator

SA Series

Product Description

The SA Series electromechanical actuators with integral motor and controls were designed specifically for the most extreme conditions when significant downtime is a serious cost. They offer absolute position control with an integral multi-turn encoder allowing for precise positioning. These advanced actuators are suitable for a wide range of applications including autonomous vehicle or robotics applications.

Rugged and Reliable

Designed to meet stringent environmental and emissions standards, all SA Series actuators are built with corrosion resistant coatings and materials, and environmentally sealed to protect against ingress from dust, sand, blowing rain, and humidity. In addition, they are tested against harsh EMI/EMC standards for better reliability than other electromechanical actuators on the market. Migrate to electric with confidence knowing the SA Series is every bit as rugged and reliable as the hydraulics they are designed to replace.

Advanced Technology

Committed to delivering a robust solution, SA Series actuators were developed with voltage enhanced IVB60 technology. While the input range of 18-32 VDC is standard, the actuator is able to convert internally up to 60 VDC to deliver maximum output.

The SA Series is optimized with BPF24 brake technology for reliable operation even with the wide input voltage range. A manual drive comes standard on the SA Series as well, allowing the user to drive the load in case of power loss.

These advancements are specifically designed to assist in field applications where autonomous technology is used or where reliability is a must.

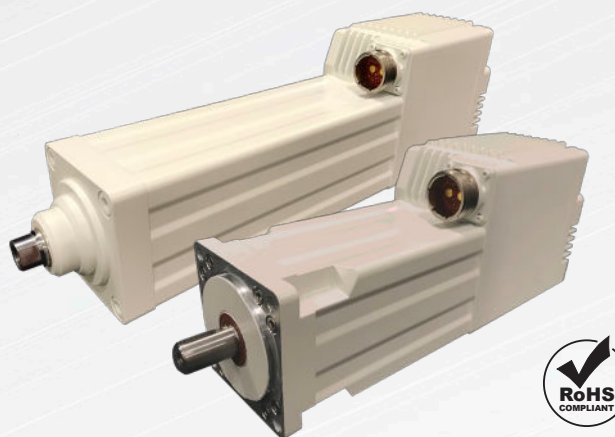

Attribute	SA-L080	Attribute	SA-R080
Input Voltage	18-32 VDC	Input Voltage	18-32 VDC
Maximum Velocity	529 mm/sec (20.8 in/sec)	Speed	2500 RPM
Maximum Force	2330 lb-f	Continuous Torque	24.7 lb-in
Application I/O	DI[6], DO[4], AI[1 +/-]	Application I/O	DI[6], DO[4], AI[1 +/-]
Position Feedback	Absolute	Position Feedback	Absolute
Communication	RS-232, CANopen	Communication	RS-232, CANopen
Operating Temperature	-40 to 50° C	Operating Temperature	-40 to 50° C
Designed to Meet	MIL-STD 461, 810	Designed to Meet	MIL-STD 461, 810
Safe Torque Off	SIL 3, Category 3	Safe Torque Off	SIL 3, Category 3
Environmental Protection	Protects against ingress from dust, sand, blowing rain, and humidity	Environmental Protection	Protects against ingress from dust, sand, blowing rain, and humidity

Product Features

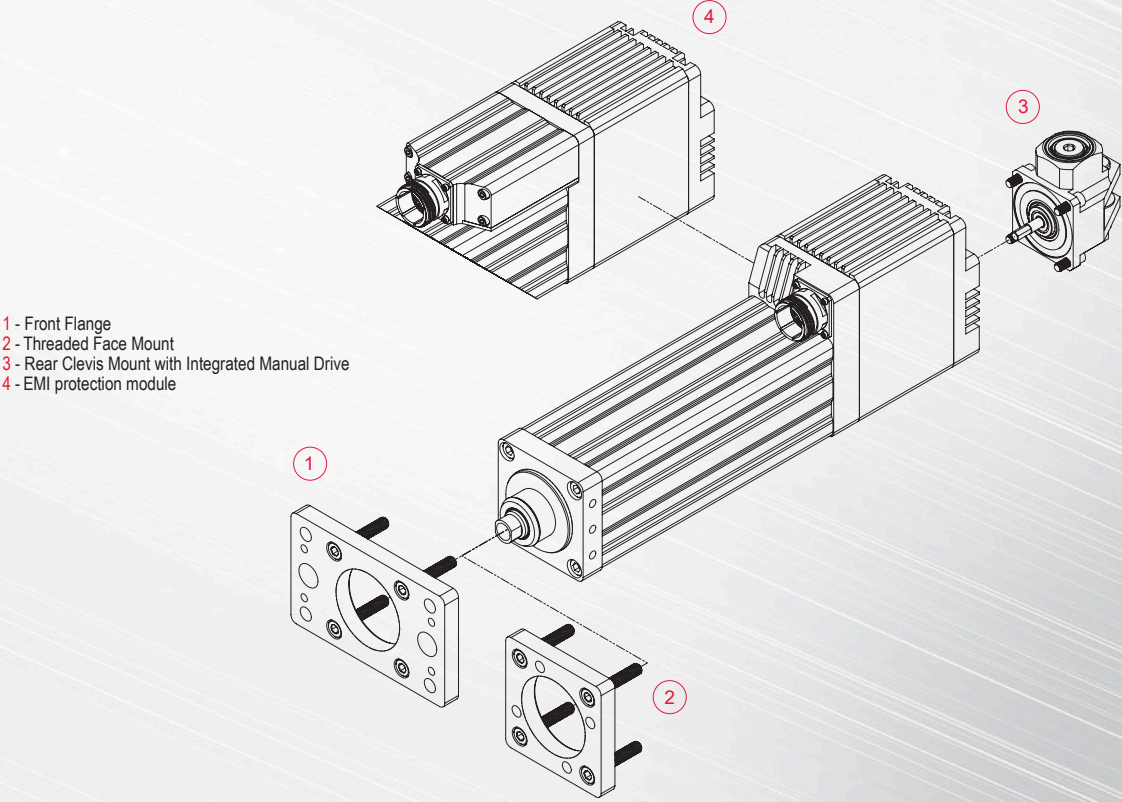
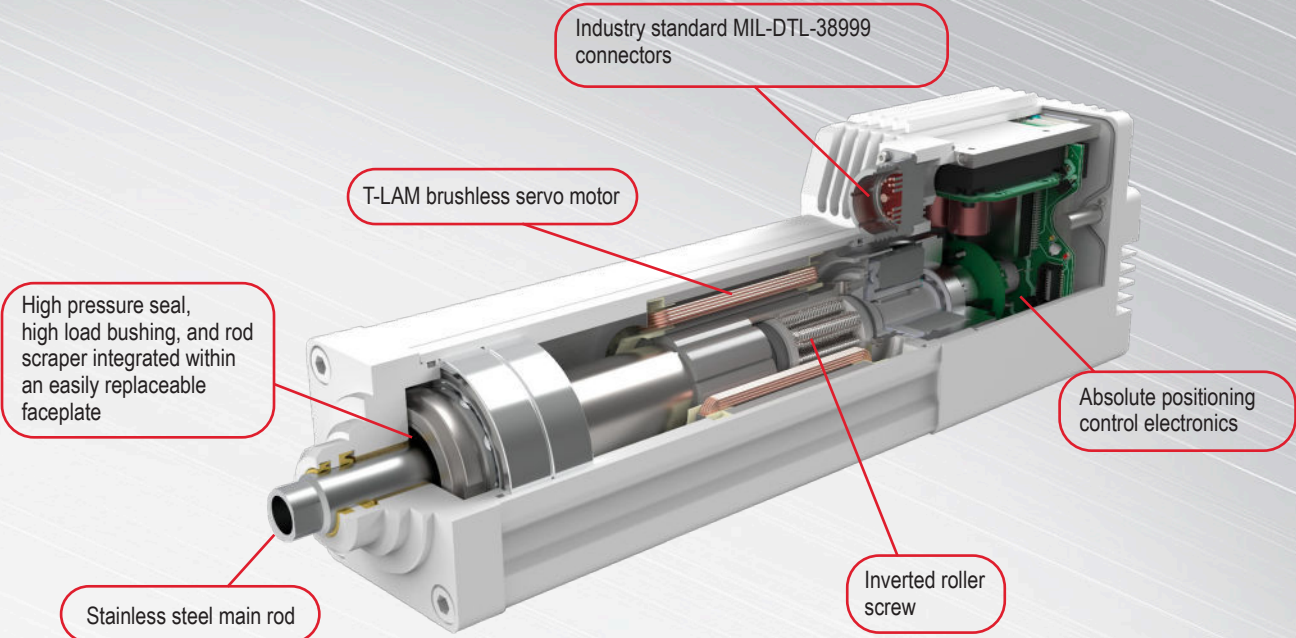

Industries & Applications

Successful applications for our SA Series intelligent electromechanical actuators include ramp lift and lower as well as arm elevation. We have extensive experience in selecting the right product and/or system for your most challenging applications. Our representatives can provide guidance to optimize system performance, eliminate premature wear, and ultimately reduce costs. Below are some of the most common applications for the SA Series. Contact one of our representatives today to discuss your application.

Autonomous vehicle or robotics applications

- End effector rotary or linear motion
- Arm elevation or azimuth

Vehicle externally operated systems

- Antennae deployment
- Tow/winch operation
- Ramp lift/lower

Driver assist technology

- Armored door assist
- Heavy duty hatch open/close operation

Field deployed mast or radar systems

- Elevation
- Precision positioning



CURTISS - WRIGHT

EXLAR[®]

Exlar Automation 18400 West 77th Street Chanhassen, MN 55317 855-620-6200 www.exlar.com