

[Return to Table of Contents](#)

KX SERIES

MEDIUM FORCE ROLLER SCREW ACTUATOR

Mount virtually any servo motor

Long stroke lengths available

High speed and long life



*Motors shown in photos
are for illustrative purposes
only and are not included
with KX Series Actuators*

KX Series Linear Actuators

KX Series

Linear Actuators

Exlar KX Series actuators offer advanced roller screw technology in varying performance levels and allow the use of third-party motors.

A Universal Design for Ultimate Flexibility

The KX Series actuator provides an ideal replacement for pneumatic and hydraulic cylinders in linear motion control applications. Unlike most suppliers who employ ballscrews, Exlar KX Series linear actuators utilize a planetary roller screw, assuring long life and high resistance to shock. This feature makes Exlar actuators far superior to alternative methods for applying all-electric linear actuation in industrial and military applications.

KX Series actuators are offered in 60, 75 and 90 mm frame sizes with dimensions and form-factor consistent with ISO Metric pneumatic cylinder specifications. This allows convenient substitution of Exlar actuators for existing pneumatic and hydraulic actuators.

KX Series actuators provides high performance planetary roller screw performance that is far superior to any other available rotary-to-linear conversion technologies. The KX Series is the ideal choice for demanding applications in industrial automation, mobile equipment, military, process control, or many other applications where millions of inches of travel under load is expected.

Operating Conditions and Usage

| Operating Conditions and Usage | | |
|--------------------------------|----|-----------|
| Efficiency: | | |
| Motor Inline | % | 80 |
| Motor Parallel | % | 80 |
| Ambient Conditions: | | |
| Standard Ambient Temperature | °C | 0 to 65 |
| Extended Ambient Temperature* | °C | -30 to 65 |
| Storage Temperature | °C | -40 to 85 |
| IP Rating | | IP65S |

*Consult Exlar for extended temperature operation.

Technical Characteristics

| Technical Characteristics | |
|---------------------------------|---|
| Frame Sizes in (mm) | 2.3 (60), 2.9 (75), 3.5 in (90) |
| Screw Leads in (mm) | 0.19 (5), 0.4 (10) |
| Standard Stroke Lengths in (mm) | 5.9 (150), 11.8 (300), 23.6 (600), 35.4 (900) |
| Force Range | up to 3,500 lbf (15 kN) |
| Maximum Speed | up to 32.8 in/sec (833 mm/s) |

| | | KX60 | KX75 | KX90 |
|------------------------|-----------------------|---------------------|---------------------|---------------------|
| Screw Lead Error | µm/1000 mm (in/ft) | G9: 200 (0.0024) | G9: 200 (0.0024) | G9: 200 (0.0024) |
| Screw Lead Backlash | mm (in) | 0.10 (0.004) | 0.10 (0.004) | 0.10 (0.004) |
| Friction Torque Values | (Nm) lbf-in | 0.34 (3) | 0.56 (5) | 0.56 (5) |

The Exlar Advantage

Universal Mounting Options

The KX Series offers a wide variety of fixed and adjustable mounting accessories consistent with NFPA inch and ISO Metric pneumatic cylinder standards. The mounting options include:

- Front Flange
- Adjustable Side Trunnions
- Rear Clevis

Standard Actuator Construction

The standard KX Series actuator design includes an anodized aluminum housing offering a high level of corrosion resistance in many environments. The standard main rod is plated steel with a stainless steel rod end insert, providing excellent wear characteristics.

Sealed Body Design

The standard body design of the KX Series provides an IP54S sealed housing. IP65S sealing is standard when an inline or parallel motor mount is specified. This feature allows the actuator to be used in applications where water spray is present.

Motor Mounting Options

The KX Series allows for complete flexibility in the type and style of motor to drive the actuator. Types of motors compatible with KX Series actuators include DC motor, stepper, and servo motors. The KX Series can be ordered as a base unit without motor mounting, allowing you to manufacture your own mount.

For convenience these actuators are available with preconfigured motor mounts. Exlar maintains a large library of motor mounting dimension information for most manufacturers' servos and stepper motors.

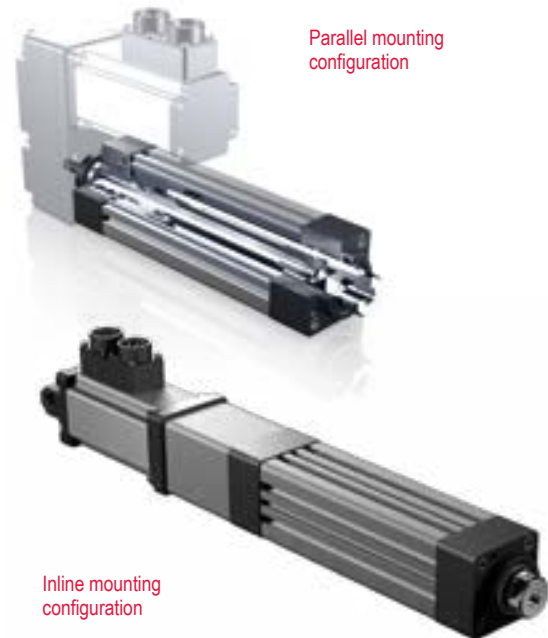

The inline mount places the motor on the input end of the actuator and allows the most compact form factor. In addition, Exlar offers a clevis mount attached to the rear of the inline-mounted motor for rear mounting.

The parallel motor mounts (side mount) utilize a belt drive system to transmit the motor torque to the actuator input shaft. Belt reductions of 1:1 and 2:1 are offered, allowing you to conveniently match the speed and output force to properly apply your KX Series actuator to your specific application.

KX Series Linear Actuators

Product Features

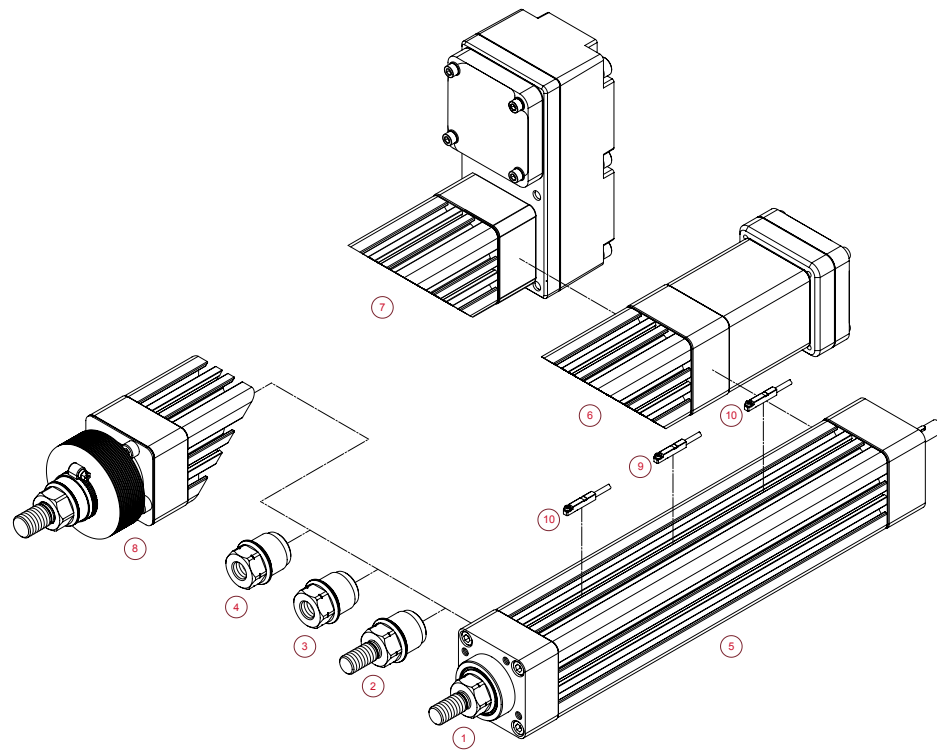
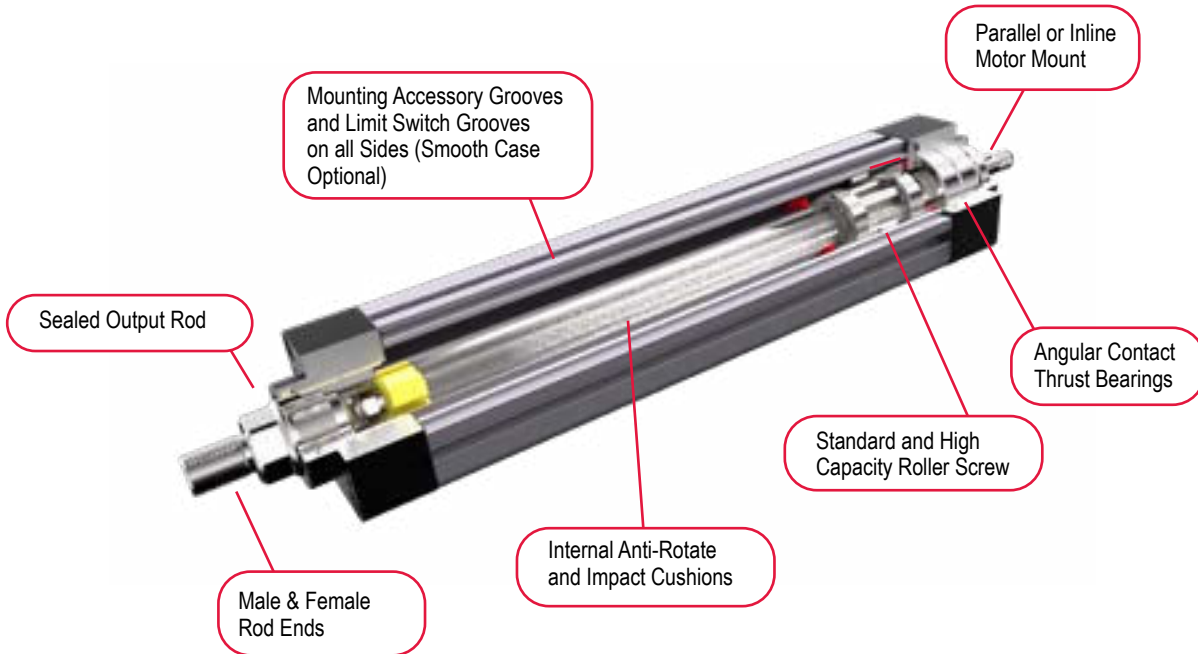

- 1-Male, US Standard thread
- 2-Male Metric thread
- 3-Female US Standard thread
- 4-Female Metric thread
- 5-Drive shaft only, no motor mount
- 6-Inline, includes shaft coupling
- 7-Parallel, 1:1 belt reduction
- 8-Protective bellows for extending rod
- 9-External Limit Switches - N.O., PNP
- 10-External Limit Switches - N.C., PNP

Industries and Applications

Hydraulic cylinder replacement
Ball screw replacement
Pneumatic cylinder replacement

Automotive

Dispensing
Automated assembly
Clamping

Food Processing

Packaging machinery
Pick and place systems

Machining

Automated flexible fixturing
Machine tool
Parts clamping
Automatic tool changers

Entertainment / Simulation

Motion simulators
Ride automation

Medical Equipment

Volumetric pumps

Plastics

Cut-offs
Die cutters
Molding
Formers

Material Handling

Indexing stages
Product sorting
Material cutting
Open / close doors
Web guidance
Wire winding
Pressing

Test

Test stands

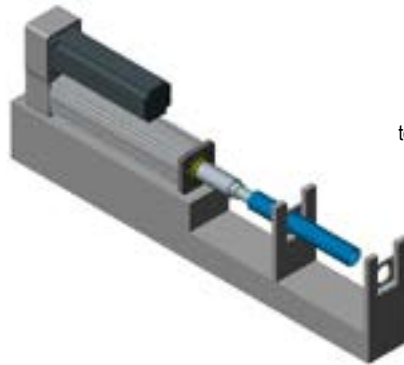

The smooth and accurate motion of Exlar's actuators combined with today's servo technology make multiple degree of freedom motion simulation applications easier to implement, cleaner and more efficient than hydraulic solutions.



DEFINITIONS:

Maximum Force: Calculated Cubic Mean Load for the application should not exceed this value. (Values are derived from the design capacity of the FT Series actuator and should not be exceeded or relied upon for continuous operation.)

Life at Maximum Force: Estimated life that can be expected from the actuator when running at Maximum Force for intermittent periods of time. (Theoretical calculation based on the Dynamic Load Rating of the actuator and using the Maximum Force rating as the Cubic Mean Load.)

C_a (Dynamic Load Rating): A design constant used when calculating the estimated travel life of the roller screw.

Maximum Input Torque: The torque required at the screw to produce the Maximum Force rating. Exceeding this value can cause permanent damage to the actuator.

Maximum Rated RPM: The maximum allowable rotational screw speed determined by either screw length limitations or the rotational speed limit of the roller screw nut.

Maximum Linear Speed: The linear speed achieved by the actuator when Maximum Rated RPM is applied to the roller screw input shaft.

Mechanical Specifications

KX60

| Models | KX | | |
|--|----------------------|--------|--------|
| | | 05 | 10 |
| Screw Lead | in | 0.1969 | 0.3937 |
| | mm | 5 | 10 |
| Maximum Force ³ | lbf | 1350 | 675 |
| | kN | 6.0 | 3.0 |
| Life at Maximum Force ¹ | in x 10 ⁶ | 1.6 | 18.2 |
| | km | 41.7 | 461.4 |
| C _a (Dynamic Load Rating) | lbf | 2738 | 2421 |
| | kN | 12.2 | 10.8 |
| Maximum Input Torque ² | lbf-in | 53 | 53 |
| | Nm | 6 | 6 |
| Max Rated RPM @ Input Shaft | RPM | 5000 | 5000 |
| Maximum Linear Speed @ Maximum Rated RPM | in/sec | 16.4 | 32.8 |
| | mm/sec | 417 | 833 |

1. See page 169 for life calculation information.
2. Input torque should be limited such that Max Force is not exceeded. For a parallel belt ratio, the input torque ratings must be divided by the belt ratio for allowable motor torque. The output force ratings remain the same.
3. Maximum allowable actuator-generated force that can be applied routinely. Exceeding this force may result in permanent damage to the actuator. For maximum allowable externally-applied axial forces, consult factory. For high force, short stroke applications, consult factory.

Weights kg (lbs)

| | | |
|---|-------------|-------|
| Base Actuator Weight (Zero Stroke) | lb | 3.7 |
| | kg | 1.7 |
| Actuator Weight Adder (Per mm of Stroke) | lb | 0.017 |
| | kg | 0.008 |
| Adder for Inline (excluding motor) | 0.42 (0.93) | |
| Adder for Parallel Drive (excluding motor) | 0.73 (1.6) | |
| Adder for Front Flange | 0.42 (0.93) | |
| Adder for Rear Clevis | 0.44 (0.98) | |
| Adder for Two Trunnions | 0.37 (0.82) | |

KX60 Inertias kg-m² (lbf-in-sec²)

| | 5 mm Lead | Add per 25 mm, 5 mm Lead |
|---|---|--|
| Base Unit - Input Drive Shaft Only | 1.480 x 10 ⁻⁵ (1.31 x 10 ⁻⁴) | 1.022 x 10 ⁻⁶ (9.045 x 10 ⁻⁶) |
| Inline Unit - w/Motor Coupling | 2.702 x 10 ⁻⁵ (2.39 x 10 ⁻⁴) | 1.022 x 10 ⁻⁶ (9.045 x 10 ⁻⁶) |
| | 10 mm Lead | Add per 25 mm, 10 mm Lead |
| Base Unit - Input Drive Shaft Only | 1.616 x 10 ⁻⁵ (1.43 x 10 ⁻⁴) | 1.173 x 10 ⁻⁶ (1.038 x 10 ⁻⁶) |
| Inline Unit - w/Motor Coupling | 2.837 x 10 ⁻⁵ (2.51 x 10 ⁻⁴) | 1.173 x 10 ⁻⁶ (1.038 x 10 ⁻⁶) |
| Parallel Drive Inertias (P10 Option) | | |
| | 5 mm Lead | Add per 25 mm, 5 mm Lead |
| 1:1 Reduction Parallel Belt Drive (66 mm) | 4.339 x 10 ⁻⁵ (3.84 x 10 ⁻⁴) | 1.022 x 10 ⁻⁶ (9.045 x 10 ⁻⁶) |
| 1:1 Reduction Parallel Belt Drive (86 mm) | 7.378 x 10 ⁻⁵ (6.53 x 10 ⁻⁴) | 1.022 x 10 ⁻⁶ (9.045 x 10 ⁻⁶) |
| 1:1 Reduction Parallel Belt Drive (96 mm) | 8.564 x 10 ⁻⁵ (7.58 x 10 ⁻⁴) | 1.022 x 10 ⁻⁶ (9.045 x 10 ⁻⁶) |
| 2:1 Reduction Parallel Belt Drive (96 mm) | 7.095 x 10 ⁻⁵ (6.28 x 10 ⁻⁴) | 2.555 x 10 ⁻⁷ (2.261 x 1 ⁻⁶) |
| | 10 mm Lead | Add per 25 mm, 10 mm Lead |
| 1:1 Reduction Parallel Belt Drive (66 mm) | 4.474 x 10 ⁻⁵ (3.96 x 10 ⁻⁴) | 1.173 x 10 ⁻⁶ (1.038 x 10 ⁻⁶) |
| 1:1 Reduction Parallel Belt Drive (86 mm) | 7.514 x 10 ⁻⁵ (6.65 x 10 ⁻⁴) | 1.173 x 10 ⁻⁶ (1.038 x 10 ⁻⁶) |
| 1:1 Reduction Parallel Belt Drive (96 mm) | 8.704 x 10 ⁻⁵ (7.70 x 10 ⁻⁴) | 1.173 x 10 ⁻⁶ (1.038 x 10 ⁻⁶) |
| 2:1 Reduction Parallel Belt Drive (96 mm) | 7.129 x 10 ⁻⁵ (6.31 x 10 ⁻⁴) | 2.931 x 10 ⁻⁷ (2.595 x 10 ⁻⁶) |
| Parallel Drive Inertias (Smooth Motor Shaft Option) | | |
| | 5 mm Lead | Add per 25 mm, 5 mm Lead |
| 1:1 Reduction Parallel Belt Drive (66 mm) | 6.015 x 10 ⁻⁵ (5.32 x 10 ⁻⁴) | 1.022 x 10 ⁻⁶ (9.045 x 10 ⁻⁶) |
| 1:1 Reduction Parallel Belt Drive (86 mm) | 1.103 x 10 ⁻⁴ (9.76 x 10 ⁻⁴) | 1.022 x 10 ⁻⁶ (9.045 x 10 ⁻⁶) |
| 1:1 Reduction Parallel Belt Drive (96 mm) | 2.176 x 10 ⁻⁴ (1.93 x 10 ⁻³) | 1.022 x 10 ⁻⁶ (9.045 x 10 ⁻⁶) |
| 2:1 Reduction Parallel Belt Drive (96 mm) | 8.768 x 10 ⁻⁵ (7.76 x 10 ⁻⁴) | 2.555 x 10 ⁻⁷ (2.261 x 10 ⁻⁶) |
| | 10 mm Lead | Add per 25 mm, 10 mm Lead |
| 1:1 Reduction Parallel Belt Drive (66 mm) | 6.150 x 10 ⁻⁵ (5.44 x 10 ⁻⁴) | 1.173 x 10 ⁻⁶ (1.038 x 10 ⁻⁶) |
| 1:1 Reduction Parallel Belt Drive (86 mm) | 1.117 x 10 ⁻⁴ (9.88 x 10 ⁻⁴) | 1.173 x 10 ⁻⁶ (1.038 x 10 ⁻⁶) |
| 1:1 Reduction Parallel Belt Drive (96 mm) | 2.190 x 10 ⁻⁴ (1.94 x 10 ⁻³) | 1.173 x 10 ⁻⁶ (1.038 x 10 ⁻⁶) |
| 2:1 Reduction Parallel Belt Drive (96 mm) | 8.802 x 10 ⁻⁵ (7.79 x 10 ⁻⁴) | 2.931 x 10 ⁻⁷ (2.595 x 10 ⁻⁶) |

*See definitions on page 123

KX75

| Models | | KX | |
|--|----------------------|--------|--------|
| | | 05 | 10 |
| Screw Lead | in | 0.1969 | 0.3937 |
| | mm | 5 | 10 |
| Maximum Force ³ | lbf | 2500 | 1250 |
| | kN | 11.1 | 5.6 |
| Life at Maximum Force ¹ | in x 10 ⁶ | 2.4 | 22.6 |
| | km | 60.7 | 573.3 |
| C _a (Dynamic Load Rating) | lbf | 5746 | 4820 |
| | kN | 25.6 | 21.4 |
| Maximum Input Torque ² | lbf-in | 98 | 98 |
| | Nm | 11 | 11 |
| Max Rated RPM @ Input Shaft | RPM | 4000 | 4000 |
| Maximum Linear Speed @ Maximum Rated RPM | in/sec | 13.1 | 26.2 |
| | mm/sec | 333 | 666 |

1. See page 169 for life calculation information.

2. Input torque should be limited such that Max Force is not exceeded. For a parallel belt ratio, the input torque ratings must be divided by the belt ratio for allowable motor torque. The output force ratings remain the same.

3. Maximum allowable actuator-generated force that can be applied routinely. Exceeding this force may result in permanent damage to the actuator. For maximum allowable externally-applied axial forces, consult factory. For high force, short stroke applications, consult factory.

Weights kg (lbs)

| | | |
|--|----|-------------|
| Base Actuator Weight (Zero Stroke) | lb | 6.75 |
| | kg | 3.06 |
| Actuator Weight Adder (Per mm of Stroke) | lb | 0.0235 |
| | kg | 0.0107 |
| Adder for Inline (excluding motor) | | 1.12 (2.46) |
| Adder for Parallel Drive (excluding motor) | | 1.84 (4.06) |
| Adder for Front Flange | | 0.87 (1.91) |
| Adder for Rear Clevis | | 0.84 (1.85) |
| Adder for Two Trunnions | | 0.71 (1.56) |

KX75 Inertias kg-m² (lbf-in-sec²)

| | 5 mm Lead | Add per 25 mm, 5 mm Lead |
|---|--|--|
| Base Unit - Input Drive Shaft Only | 9.26 x 10 ⁻⁵ (8.20 x 10 ⁻⁴) | 3.13 x 10 ⁻⁶ (2.77 x 10 ⁻⁵) |
| Inline Unit - w/Motor Coupling | 1.25 x 10 ⁻⁴ (1.11 x 10 ⁻³) | 3.13 x 10 ⁻⁶ (2.77 x 10 ⁻⁵) |
| | 10 mm Lead | Add per 25 mm, 10 mm Lead |
| Base Unit - Input Drive Shaft Only | 9.48 x 10 ⁻⁵ (8.39 x 10 ⁻⁴) | 3.32 x 10 ⁻⁶ (2.94 x 10 ⁻⁵) |
| Inline Unit - w/Motor Coupling | 1.44 x 10 ⁻⁴ (1.28 x 10 ⁻³) | 3.32 x 10 ⁻⁶ (2.94 x 10 ⁻⁵) |
| Parallel Drive Inertias (P10 Option) | | |
| | 5 mm Lead | Add per 25 mm, 5 mm Lead |
| 1:1 Reduction Parallel Belt Drive (86 mm) | 2.29 x 10 ⁻⁴ (2.03 x 10 ⁻³) | 3.13 x 10 ⁻⁶ (2.77 x 10 ⁻⁵) |
| 1:1 Reduction Parallel Belt Drive (96 mm) | 3.19 x 10 ⁻⁴ (2.82 x 10 ⁻³) | 3.13 x 10 ⁻⁶ (2.77 x 10 ⁻⁵) |
| 1:1 Reduction Parallel Belt Drive (130 mm) | 5.96 x 10 ⁻⁴ (5.28 x 10 ⁻³) | 3.13 x 10 ⁻⁶ (2.77 x 10 ⁻⁵) |
| 2:1 Reduction Parallel Belt Drive (130 mm) | 2.82 x 10 ⁻⁴ (2.50 x 10 ⁻³) | 7.83 x 10 ⁻⁷ (6.93 x 10 ⁻⁶) |
| | 10 mm Lead | Add per 25 mm, 10 mm Lead |
| 1:1 Reduction Parallel Belt Drive (86 mm) | 2.31 x 10 ⁻⁴ (2.05 x 10 ⁻³) | 3.32 x 10 ⁻⁶ (2.94 x 10 ⁻⁵) |
| 1:1 Reduction Parallel Belt Drive (96 mm) | 3.21 x 10 ⁻⁴ (2.84 x 10 ⁻³) | 3.32 x 10 ⁻⁶ (2.94 x 10 ⁻⁵) |
| 1:1 Reduction Parallel Belt Drive (130 mm) | 5.98 x 10 ⁻⁴ (5.30 x 10 ⁻³) | 3.32 x 10 ⁻⁶ (2.94 x 10 ⁻⁵) |
| 2:1 Reduction Parallel Belt Drive (130 mm) | 2.83 x 10 ⁻⁴ (2.51 x 10 ⁻³) | 8.30 x 10 ⁻⁷ (7.36 x 10 ⁻⁶) |
| Parallel Drive Inertias (Smooth Motor Shaft Option) | | |
| | 5 mm Lead | Add per 25 mm, 5 mm Lead |
| 1:1 Reduction Parallel Belt Drive (86 mm) | 2.84 x 10 ⁻⁴ (2.51 x 10 ⁻³) | 3.13 x 10 ⁻⁶ (2.77 x 10 ⁻⁵) |
| 1:1 Reduction Parallel Belt Drive (96 mm) | 4.25 x 10 ⁻⁴ (3.76 x 10 ⁻³) | 3.13 x 10 ⁻⁶ (2.77 x 10 ⁻⁵) |
| 1:1 Reduction Parallel Belt Drive (130 mm) | 7.33 x 10 ⁻⁴ (6.48 x 10 ⁻³) | 3.13 x 10 ⁻⁶ (2.77 x 10 ⁻⁵) |
| 2:1 Reduction Parallel Belt Drive (130 mm) | 3.32 x 10 ⁻⁴ (2.94 x 10 ⁻³) | 7.83 x 10 ⁻⁷ (6.93 x 10 ⁻⁶) |
| | 10 mm Lead | Add per 25 mm, 10 mm Lead |
| 1:1 Reduction Parallel Belt Drive (86 mm) | 2.86 x 10 ⁻⁴ (2.53 x 10 ⁻³) | 3.32 x 10 ⁻⁶ (2.94 x 10 ⁻⁵) |
| 1:1 Reduction Parallel Belt Drive (96 mm) | 4.27 x 10 ⁻⁴ (3.78 x 10 ⁻³) | 3.32 x 10 ⁻⁶ (2.94 x 10 ⁻⁵) |
| 1:1 Reduction Parallel Belt Drive (130 mm) | 7.35 x 10 ⁻⁴ (6.50 x 10 ⁻³) | 3.32 x 10 ⁻⁶ (2.94 x 10 ⁻⁵) |
| 2:1 Reduction Parallel Belt Drive (130 mm) | 3.33 x 10 ⁻⁴ (2.94 x 10 ⁻³) | 8.30 x 10 ⁻⁷ (7.35 x 10 ⁻⁶) |

*See definitions on page 123

KX Series Linear Actuators

KX90

| Models | KX | | |
|--|----------------------|--------|--------|
| | | 05 | 10 |
| Screw Lead | in | 0.1969 | 0.3937 |
| | mm | 5 | 10 |
| Maximum Force ³ | lbf | 3500 | 1750 |
| | kN | 15.6 | 7.8 |
| Life at Maximum Force ¹ | in x 10 ⁶ | 7.1 | 90.4 |
| | km | 179.6 | 2295 |
| C _a (Dynamic Load Rating) | lbf | 11548 | 10715 |
| | kN | 51.4 | 47.7 |
| Maximum Input Torque ² | lbf-in | 137 | 137 |
| | Nm | 16 | 16 |
| Max Rated RPM @ Input Shaft | RPM | 3000 | 3000 |
| Maximum Linear Speed @ Maximum Rated RPM | in/sec | 9.8 | 19.7 |
| | mm/sec | 250 | 500 |

1. See page 169 for life calculation information.

2. Input torque should be limited such that Max Force is not exceeded. For a parallel belt ratio, the input torque ratings must be divided by the belt ratio for allowable motor torque. The output force ratings remain the same.

3. Maximum allowable actuator-generated force that can be applied routinely. Exceeding this force may result in permanent damage to the actuator. For maximum allowable externally-applied axial forces, consult factory. For high force, short stroke applications, consult factory.

Weights kg (lbs)

| | | |
|---|--------------|--------|
| Base Actuator Weight (Zero Stroke) | lb | 11.96 |
| | kg | 5.42 |
| Actuator Weight Adder (Per mm of Stroke) | lb | 0.0366 |
| | kg | 0.016 |
| Adder for Inline (excluding motor) | 1.51 (3.35) | |
| Adder for Parallel Drive (excluding motor) | 2.62 (5.80) | |
| Adder for Front Flange | 1.54 (3.40) | |
| Adder for Rear Clevis | 1.45 (3.21) | |
| Adder for Two Trunnions | 0.80 (1.768) | |

KX90 Inertias kg-m² (lbf-in-sec²)

| | 5 mm Lead | Add per 25 mm, 5 mm Lead |
|---|---|---|
| Base Unit - Input Drive Shaft Only | 2.97×10^{-4} (2.63×10^{-3}) | 1.11×10^{-5} (9.80×10^{-5}) |
| Inline Unit - w/Motor Coupling | 3.84×10^{-4} (3.40×10^{-3}) | 1.11×10^{-5} (9.80×10^{-5}) |
| | 10 mm Lead | Add per 25 mm, 10 mm Lead |
| Base Unit - Input Drive Shaft Only | 3.00×10^{-4} (2.66×10^{-3}) | 1.13×10^{-5} (1.00×10^{-4}) |
| Inline Unit - w/Motor Coupling | 3.87×10^{-4} (3.43×10^{-3}) | 1.13×10^{-5} (1.00×10^{-4}) |
| Parallel Drive Inertias (P10 Option) | | |
| | 5 mm Lead | Add per 25 mm, 5 mm Lead |
| 1:1 Reduction Parallel Belt Drive (96 mm) | 5.12×10^{-4} (4.53×10^{-3}) | 1.11×10^{-5} (9.80×10^{-5}) |
| 1:1 Reduction Parallel Belt Drive (130 mm) | 7.98×10^{-4} (7.07×10^{-3}) | 1.11×10^{-5} (9.80×10^{-5}) |
| 2:1 Reduction Parallel Belt Drive (130 mm) | 3.41×10^{-4} (3.02×10^{-3}) | 2.77×10^{-6} (2.45×10^{-5}) |
| | 10 mm Lead | Add per 25 mm, 10 mm Lead |
| 1:1 Reduction Parallel Belt Drive (96 mm) | 5.15×10^{-4} (4.56×10^{-3}) | 1.13×10^{-5} (1.00×10^{-4}) |
| 1:1 Reduction Parallel Belt Drive (130 mm) | 8.02×10^{-4} (7.10×10^{-3}) | 1.13×10^{-5} (1.00×10^{-4}) |
| 2:1 Reduction Parallel Belt Drive (130 mm) | 3.42×10^{-4} (3.03×10^{-3}) | 2.82×10^{-6} (2.50×10^{-5}) |
| Parallel Drive Inertias (Smooth Motor Shaft Option) | | |
| | 5 mm Lead | Add per 25 mm, 5 mm Lead |
| 1:1 Reduction Parallel Belt Drive (96 mm) | 6.18×10^{-4} (5.47×10^{-3}) | 1.11×10^{-5} (9.80×10^{-5}) |
| 1:1 Reduction Parallel Belt Drive (130 mm) | 9.35×10^{-4} (8.27×10^{-3}) | 1.11×10^{-5} (9.80×10^{-5}) |
| 2:1 Reduction Parallel Belt Drive (130 mm) | 3.91×10^{-4} (3.46×10^{-3}) | 2.77×10^{-6} (2.45×10^{-5}) |
| | 10 mm Lead | Add per 25 mm, 10 mm Lead |
| 1:1 Reduction Parallel Belt Drive (96 mm) | 6.21×10^{-4} (5.50×10^{-3}) | 1.13×10^{-5} (1.00×10^{-4}) |
| 1:1 Reduction Parallel Belt Drive (130 mm) | 9.38×10^{-4} (8.30×10^{-3}) | 1.13×10^{-5} (1.00×10^{-4}) |
| 2:1 Reduction Parallel Belt Drive (130 mm) | 3.92×10^{-4} (3.47×10^{-3}) | 2.82×10^{-6} (2.50×10^{-5}) |

*See definitions on page 123

Estimated Service Life

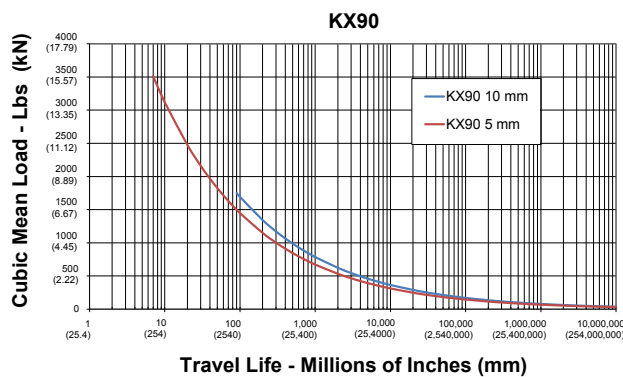
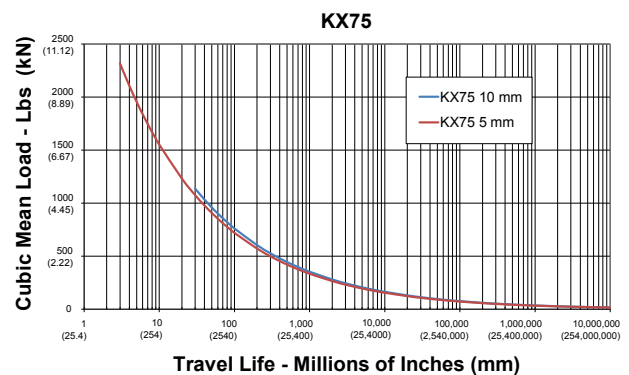
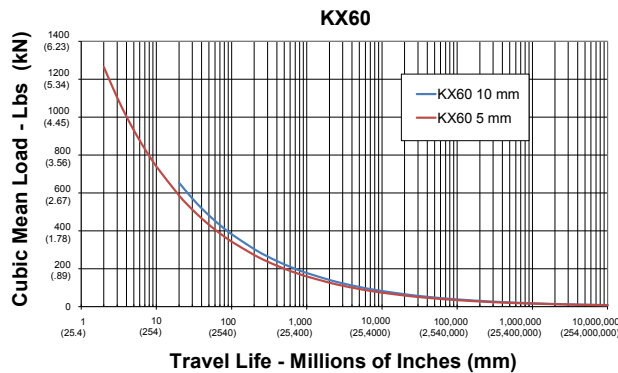

Service Life Estimate Assumptions:

- Sufficient quality and quantity of lubrication is maintained throughout service life (please refer to engineering reference on page 169 for lubrication interval estimates.)
- Bearing and screw temperature between 20° C and 40° C
- No mechanical hard stops (external or internal) or impact loads
- No external side loads
- Does not apply to short stroke, high frequency applications such as fatigue testing or short stroke, high force applications such as pressing. (For information on calculating estimating life for unique applications please refer to the engineering reference on page 169.

The L_{10} expected life of a roller screw linear actuator is expressed as the linear travel distance that 90% of properly maintained roller screws manufactured are expected to meet or exceed. This is not a guarantee and these charts should be used for estimation purposes only.

The underlying formula that defines this value is:
Travel life in millions of inches, where:

$$L_{10} = \left(\frac{C_a}{F_{cml}} \right)^3 \times \ell$$

C_a = Dynamic load rating (lbf)
 F_{cml} = Cubic mean applied load (lbf)
 ℓ = Roller screw lead (inches)

For additional details on calculating estimated service life, please refer to the Engineering Reference, page 169.

Data Curves

Critical Speed vs Stroke Length:

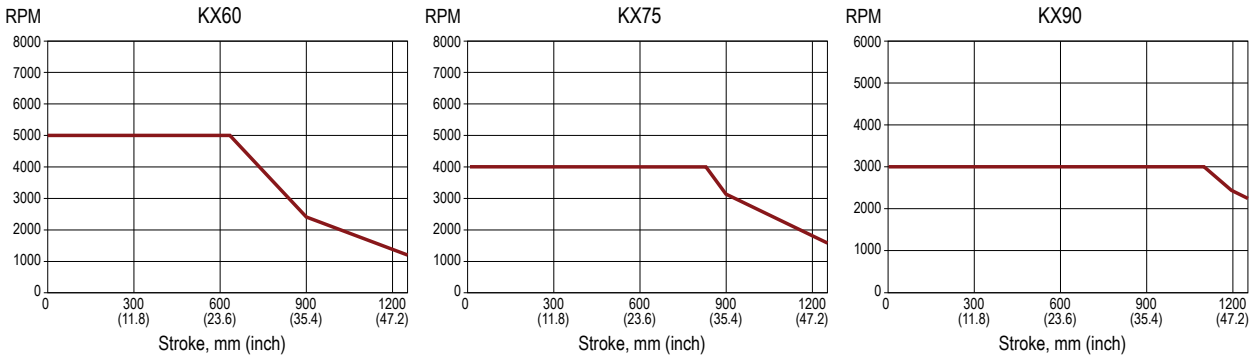

— Actuator Rated Speed
 speed at which we have tested and rated the actuator
 * With longer stroke length actuators, the rated speed of the actuator is determined by the critical speed

Maximum Side Load:

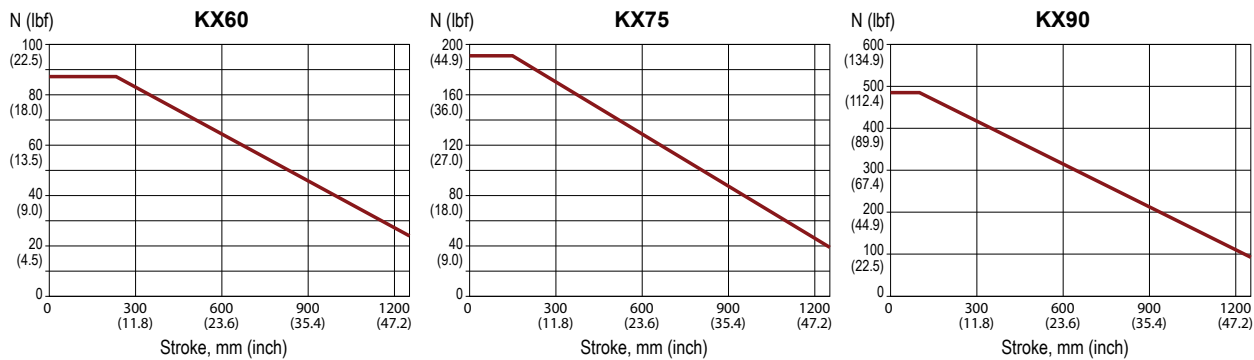

Rated Force vs Stroke:

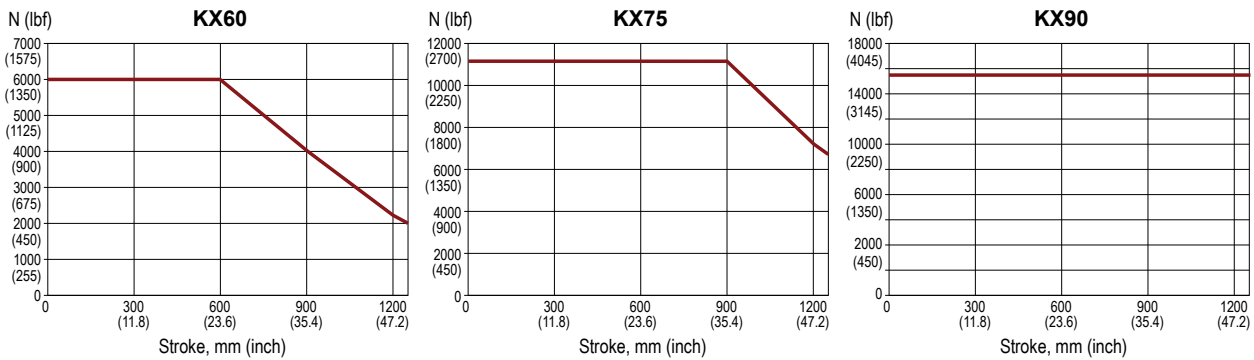

Options

PB = Protective Bellows

This option provides an accordion style protective bellows to protect the main actuator rod from damage due to abrasives or other contaminants in the environment in which the actuator must survive. The standard material of this bellows is S2 Neoprene Coated Nylon, Sewn Construction. This standard bellows is rated for environmental temperatures of -40 to 250 degrees F. Longer strokes may require the main rod of the actuator to be extended beyond standard length. Not available with extended tie rod mounting option. Please contact your local sales representative.

L1 ... L6 = Adjustable External Travel Switches

This option allows up to 3 external switches to be included. These switches provide travel indication to the controller and are adjustable.

KX Series Accessories

| KX60 | KX75 | KX90 | |
|--|-----------------|--------------------|---|
| | | | Mounting Attachments (including proper number of standard T nuts and screws) |
| KSFF-60 | KSFF-75 | KSFF-90 | Front Flange Attachment |
| KSST-60 | KSST-75 | KSST-90 | Side Trunnions (includes 2) |
| KSRC-60 | KSRC-75 | KSRC-90 | Rear Clevis (includes pins) |
| KSMT-60 | KSMT-75 | KSMT-90 | Metric Side Trunnion |
| KSMC-60 | KSMC-75 | KSMC-90 | Metric Rear Clevis (includes pins) |
| | | | Rod End Attachments |
| SRM050 | SRM075 | SRM075 | Front Spherical Rod Eye, fits "M" Rod only |
| REI050 | RE075 | RE075 | Front Rod Eye, fits "M" Rod only |
| RCI050 | RC075 | RC075 | Front Rod Clevis, fits "M" Rod only |
| | | | Clevis Pins |
| Limit Switches (if required in addition to L1, L2, L3 option in actuator model) | | | |
| Option | Quantity | Part Number | Description |
| L1 | 1 | 43403 | Normally Open PNP Limit Switch (10-30 VDC, 1m, 3 wire embedded cable) |
| L2 | 2 | 43404 | Normally Closed PNP Limit Switch (10-30 VDC, 1m, 3 wire embedded cable) |
| L3 | 1 | 43403 | Normally Open PNP Limit Switch (10-30 VDC, 1m, 3 wire embedded cable) |
| | 2 | 43404 | Normally Closed PNP Limit Switch (10-30 VDC, 1m, 3 wire embedded cable) |
| L4 | 1 | 67634 | Normally Open NPN Limit Switch (10-30 VDC, 1m, 3 wire embedded cable) |
| L5 | 2 | 67635 | Normally Closed NPN Limit Switch (10-30 VDC, 1m, 3 wire embedded cable) |
| L6 | 1 | 67634 | Normally Open NPN Limit Switch (10-30 VDC, 1m, 3 wire embedded cable) |
| | 2 | 67635 | Normally Closed NPN Limit Switch (10-30 VDC, 1m, 3 wire embedded cable) |

Consult your local sales representative to discuss maximum stroke length allowable with your final configuration.

Dimensions

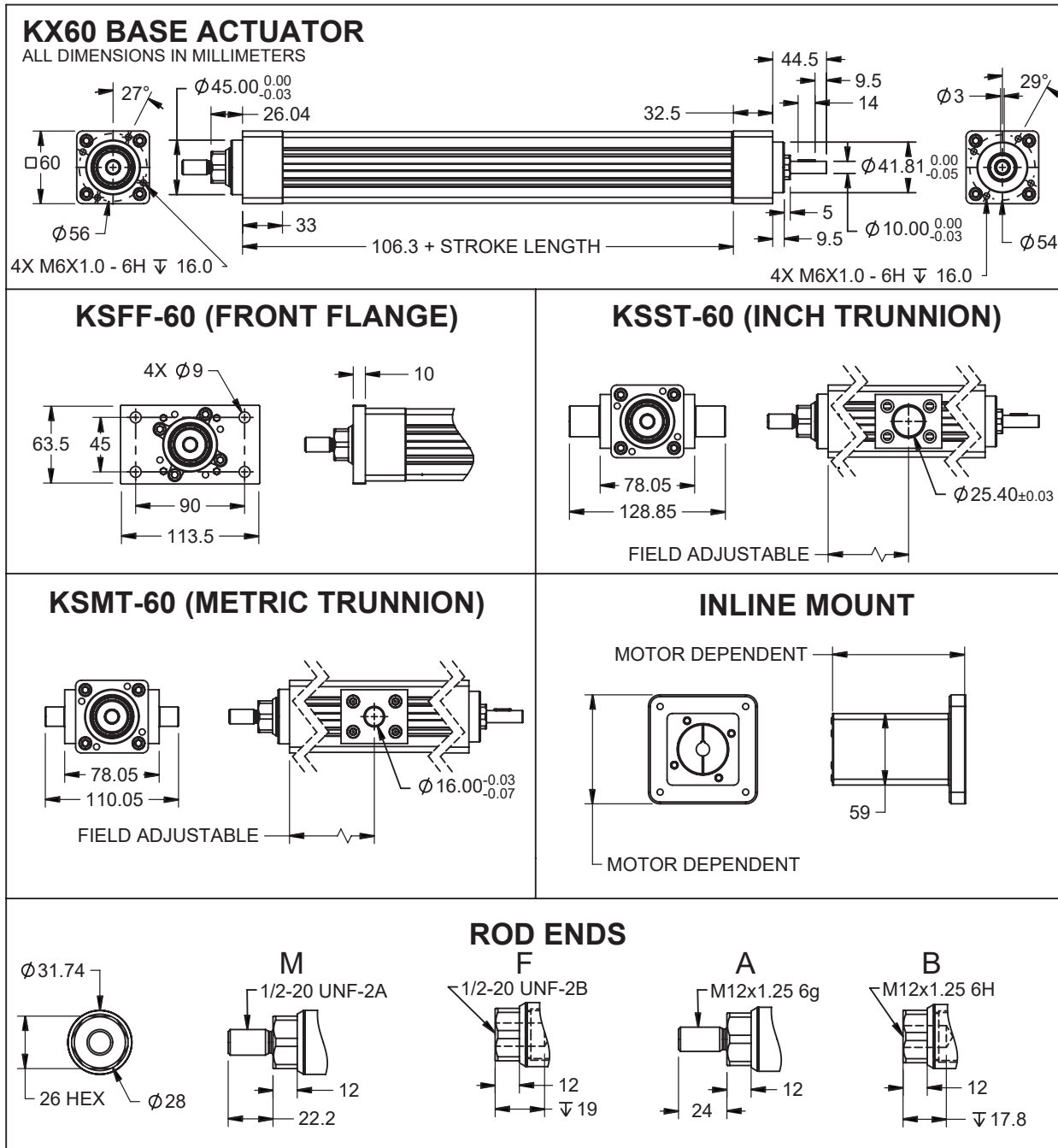

Pre-sale drawings and models are representative and are subject to change. Certified drawings and models are available for a fee. Consult your local Exlar representative for details.

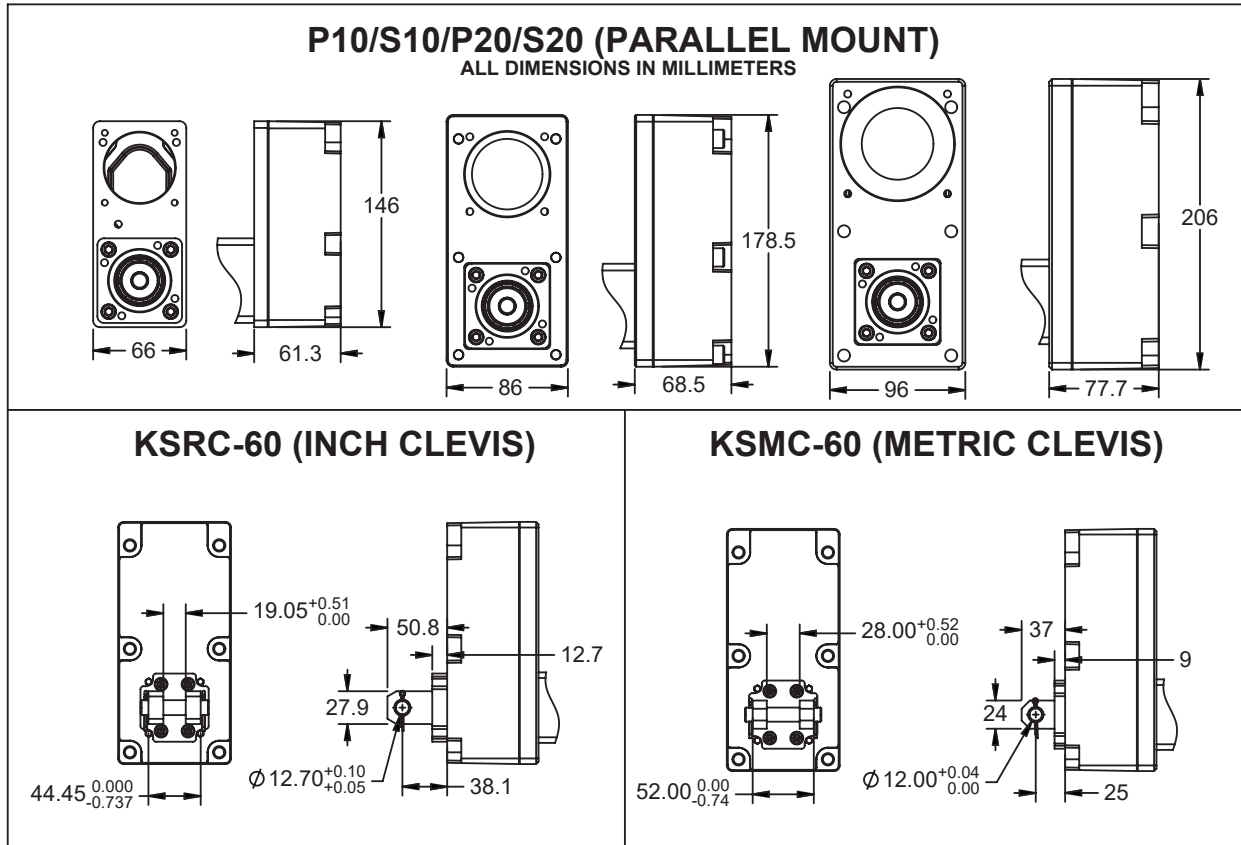

KX Series Linear Actuators

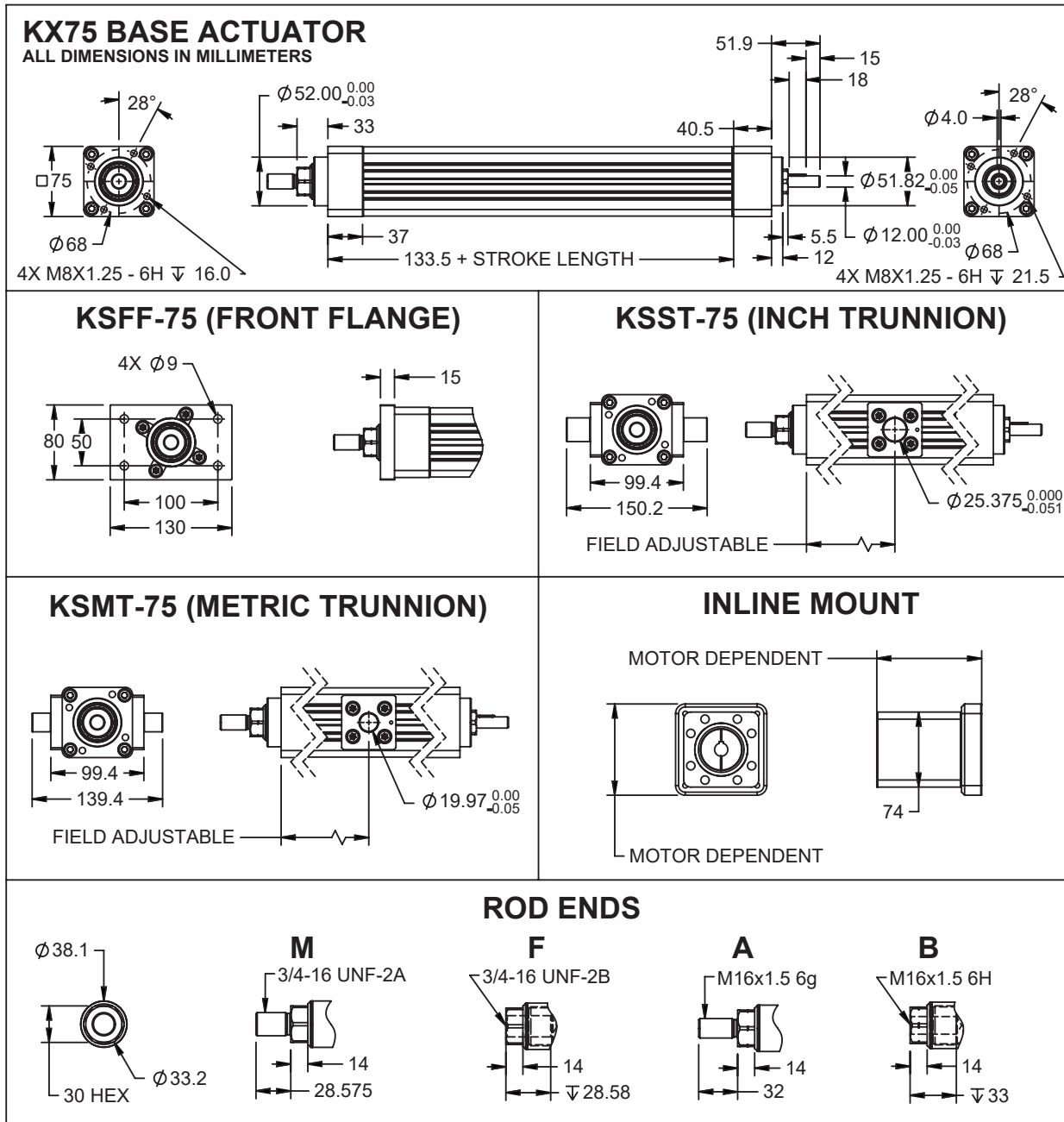

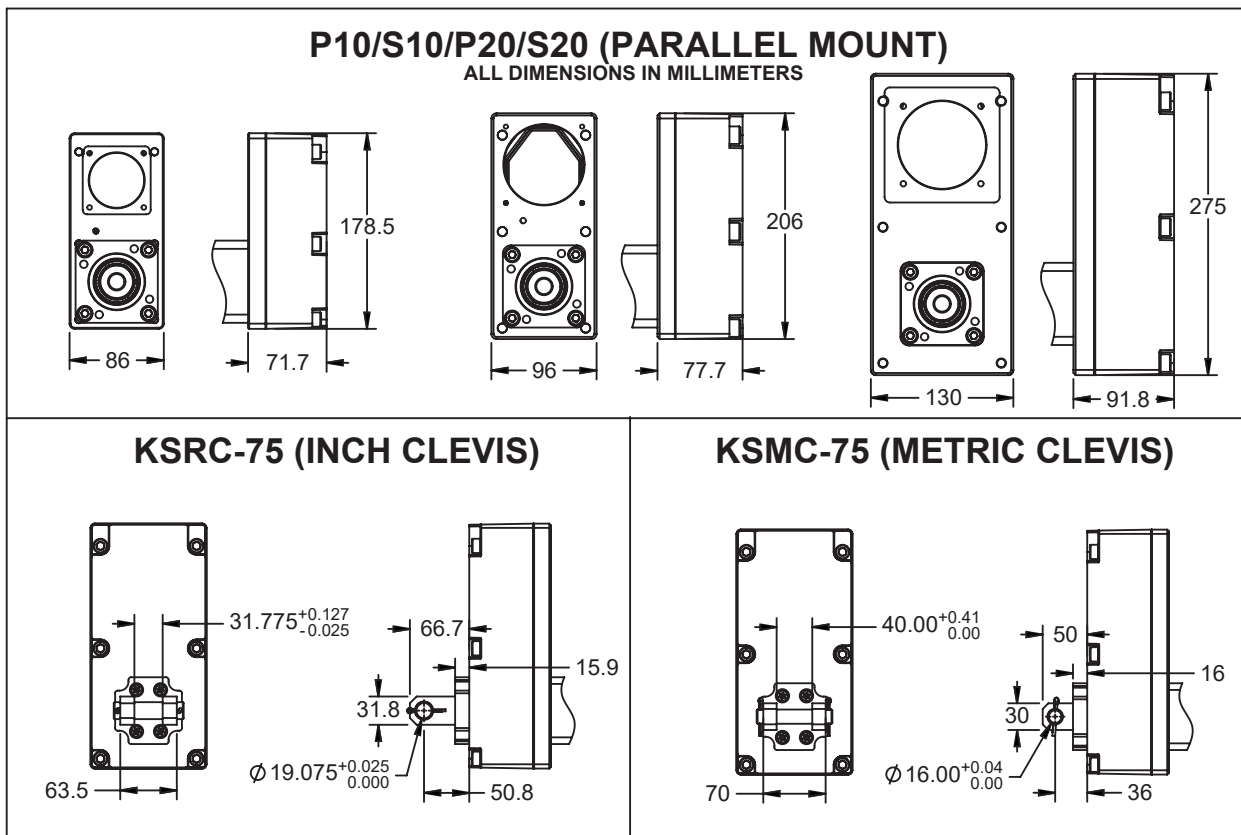

Pre-sale drawings and models are representative and are subject to change. Certified drawings and models are available for a fee. Consult your local Exlar representative for details.

KX Series Linear Actuators

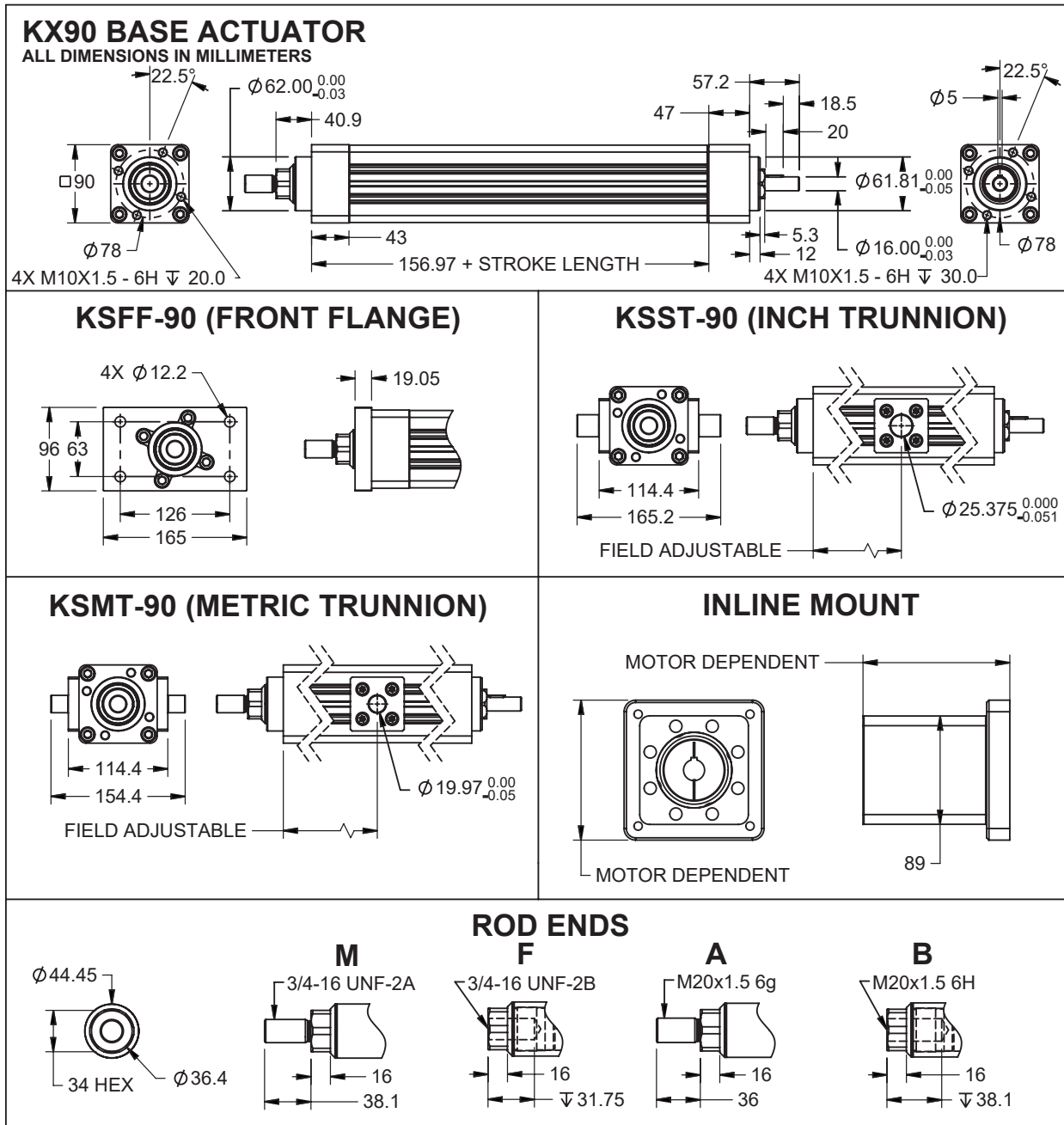

P10/S10/P20/S20 (PARALLEL MOUNT)

ALL DIMENSIONS IN MILLIMETERS

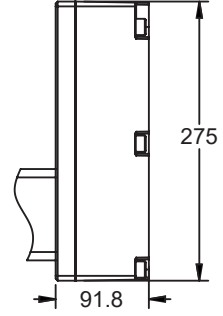
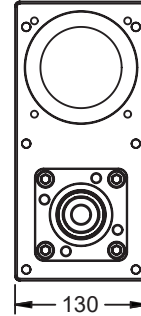
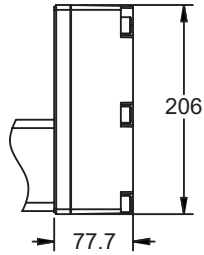
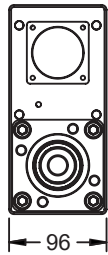

KSRC-90 (INCH CLEVIS)

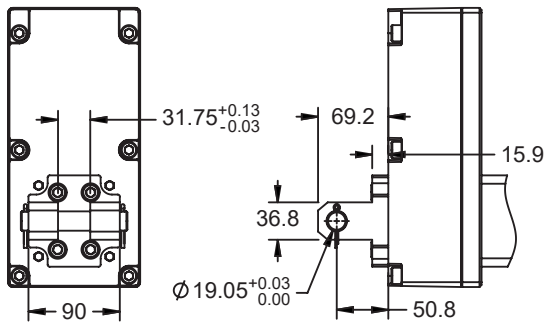

KSMC-90 (METRIC CLEVIS)

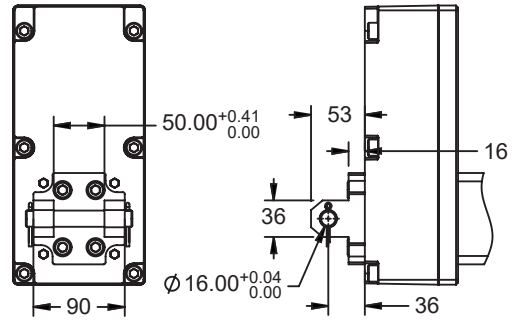

KX Series Linear Actuators

Motor Mount Drawing

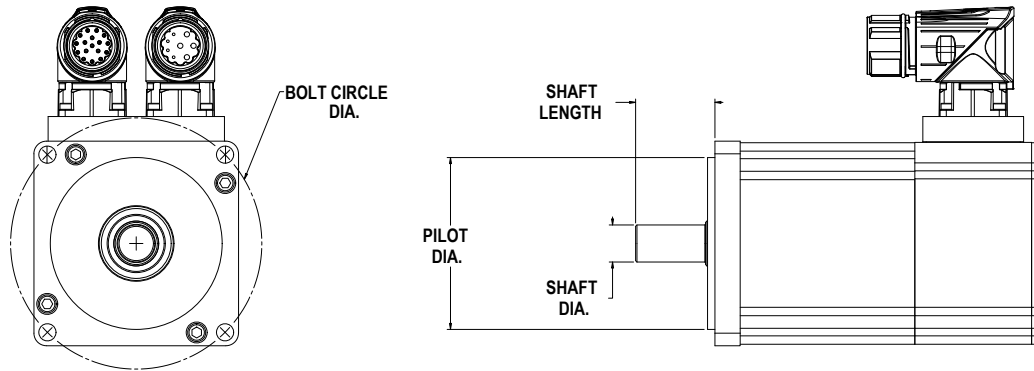

KX60 Motor Mount Codes

| Bolt Circle Diameter (mm) | Pilot Diameter (mm) | Shaft Diameter (mm) | Shaft Length (mm) | Key Width (mm) | Motor Mount Code |
|---------------------------|---------------------|---------------------|-------------------|----------------|------------------|
| 63 | 45 | 14 | 38 | 5 | GEB |
| 63 | 50a | 12 | 36 | 4 | GEA |
| 68 | 60 | 12 | 30 | 4 | GFB |
| 68 | 60 | 16 | 48 | 5 | GFA |
| 70 | 50 | 14 | 30 | 5 | JGA |
| 70 | 50 | 16 | 30 | 5 | GGB |
| 70 | 50 | 16 | 37 | 5 | GGA |
| 75 | 60 | 11 | 23 | 4 | IHA |
| 75 | 60 | 14 | 30 | 5 | IHB |
| 90 | 60 | 19 | 40 | 6 | JKF |
| 90 | 70 | 14 | 30 | 5 | JKD |
| 90 | 70 | 16 | 35 | NA | JKC |
| 90 | 70 | 16 | 40 | 5 | JKG |
| 90 | 70 | 19 | 40 | 6 | JKA |
| 95 | 50 | 14 | 30 | 5 | ILA |
| 95 | 65 | 14 | 30 | 5 | ILB |
| 100 | 80 | 10 | 32 | 3 | IMD |
| 100 | 80 | 14 | 30 | 5 | IMA |
| 100 | 80 | 14 | 40 | 5 | JMC |
| 100 | 80 | 16 | 40 | 5 | IMB |
| 100 | 80 | 19 | 40 | 6 | IMC |

KX75 Motor Mount Codes

| Bolt Circle Diameter (mm) | Pilot Diameter (mm) | Shaft Diameter (mm) | Shaft Length (mm) | Key Width (mm) | Motor Mount Code |
|---------------------------|---------------------|---------------------|-------------------|----------------|------------------|
| 68 | 60 | 16 | 48 | 5 | GFA |
| 70 | 50 | 16 | 40 | 5 | GGA |
| 75 | 60 | 16 | 48 | 5 | GHA |
| 85 | 70 | 22 | 56 | 6 | GIA |
| 90 | 60 | 19 | 40 | 6 | JKF |
| 90 | 70 | 16 | 40 | 5 | JKG |
| 90 | 70 | 19 | 40 | 6 | JKA |
| 100 | 80 | 14 | 40 | 5 | JMC |
| 100 | 80 | 16 | 40 | 5 | IMB |
| 100 | 80 | 19 | 40 | 6 | IMC |
| 100 | 80 | 19 | 55 | 6 | JMD |
| 100 | 80 | 22 | 48 | 6 | GMA |
| 115 | 95 | 19 | 40 | 6 | INA |
| 115 | 95 | 19 | 55 | 6 | JNC |
| 115 | 95 | 22 | 45 | 8 | JND |
| 115 | 95 | 22 | 70 | NA | JNB |
| 115 | 95 | 24 | 45 | 8 | JNA |
| 115 | 95 | 24 | 50 | 8 | INB |
| 130 | 95 | 19 | 40 | 6 | IPC |
| 130 | 95 | 24 | 50 | 8 | IPD |
| 130 | 110 | 19 | 40 | 6 | IPA |
| 130 | 110 | 24 | 50 | 8 | IPB |
| 145 | 110 | 19 | 40 | 6 | JQJ |
| 145 | 110 | 19 | 55 | 5 | JQG |
| 145 | 110 | 19 | 55 | 6 | JQK |
| 145 | 110 | 22 | 55 | 8 | JQH |
| 145 | 110 | 22 | 55 | 6 | JQF |
| 145 | 110 | 22 | 70 | 8 | JQE |

KX90 Motor Mount Codes

| Bolt Circle Diameter (mm) | Pilot Diameter (mm) | Shaft Diameter (mm) | Shaft Length (mm) | Key Width (mm) | Motor Mount Code |
|---------------------------|---------------------|---------------------|-------------------|----------------|------------------|
| 70 | 50 | 16 | 40 | 5 | GGA |
| 75 | 60 | 16 | 48 | 5 | GHA |
| 85 | 70 | 22 | 56 | 6 | GIA |
| 90 | 60 | 19 | 40 | 6 | JKF |
| 90 | 70 | 16 | 40 | 5 | JKG |
| 90 | 70 | 19 | 40 | 6 | JKA |
| 100 | 80 | 14 | 40 | 5 | JMC |
| 100 | 80 | 16 | 40 | 5 | IMB |
| 100 | 80 | 19 | 40 | 6 | IMC |
| 100 | 80 | 19 | 55 | 6 | JMD |
| 100 | 80 | 20 | 40 | 6 | GMB |
| 100 | 80 | 22 | 48 | 6 | GMA |
| 115 | 95 | 19 | 40 | 6 | INA |
| 115 | 95 | 19 | 55 | 6 | JNC |
| 115 | 95 | 22 | 45 | 8 | JND |
| 115 | 95 | 22 | 70 | NA | JNB |
| 115 | 95 | 24 | 45 | 8 | JNA |
| 115 | 95 | 24 | 50 | 8 | INB |
| 130 | 95 | 19 | 40 | 6 | IPC |
| 130 | 95 | 24 | 50 | 8 | IPD |
| 130 | 110 | 19 | 40 | 6 | IPA |
| 130 | 110 | 24 | 50 | 8 | IPB |
| 145 | 110 | 19 | 40 | 6 | JQJ |
| 145 | 110 | 19 | 55 | 5 | JQG |
| 145 | 110 | 19 | 55 | 6 | JQK |
| 145 | 110 | 22 | 55 | 8 | JQH |
| 145 | 110 | 22 | 55 | 6 | JQF |
| 145 | 110 | 22 | 70 | 8 | JQE |
| 145 | 110 | 24 | 55 | 8 | JQD |
| 145 | 110 | 24 | 65 | 8 | JQC |
| 145 | 110 | 28 | 55 | 8 | JQB |
| 145 | 110 | 28 | 63 | 8 | JQA |

[Return to Table of Contents](#)

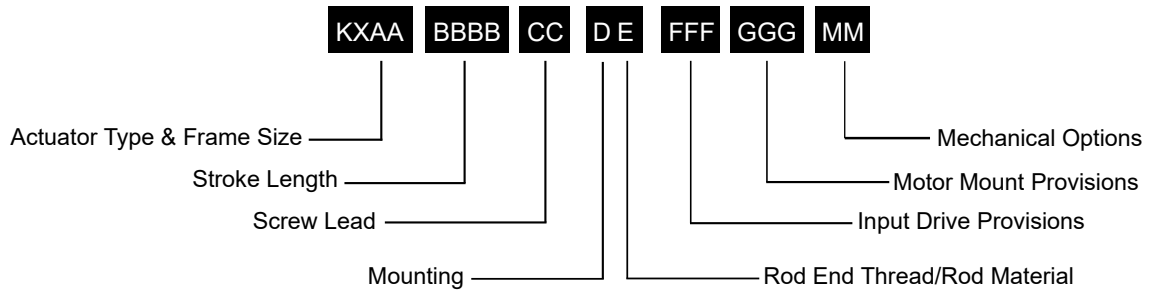

Actuator Series

KX = High Capacity Roller Screw

AA = Actuator Frame Size

60 = 60 mm (2.375 inch)
75 = 75 mm (2.95 inch)
90 = 90 mm (3.54 inch)

BBBB = Stroke Length (mm)

0150 = 150 mm (5.9 inch)
0300 = 300 mm (11.8 inch)
0600 = 600 mm (23.6 inch)
0900 = 900 mm (35.4 inch)

CC = Lead (linear motion per screw revolution)

05 = 5 mm (0.2 inch)
10 = 10 mm (0.4 inch)

D = Mounting Options

N = None, Base Unit
C = Rear Clevis
F = Front Flange
G = Metric Rear Clevis
T = Side Trunnion
Q = Metric Side Trunnion

E = Rod Options

M = Male, US Standard thread
A = Male Metric thread
F = Female US Standard thread
B = Female Metric thread

FFF = Input Drive Provisions

NMT = Drive shaft only, no motor mount
ISC = Inline, includes shaft coupling
Keyed Motor Shaft Options
P10 = Parallel, 1:1 belt reduction
P20 = Parallel, 2:1 belt reduction
Smooth Motor Shaft Options
S10 = Parallel, 1:1 belt reduction
S20 = Parallel, 2:1 belt reduction

GGG = Motor Mount Provisions ¹

See page 135-137 for Motor Mount Code.

MM = Mechanical Options ²

PB = Protective bellows for extending rod

Limit Switches

L1 = One N.O., PNP
L2 = Two N.C., PNP
L3 = One N.O. PNP & two N.C., PNP
L4 = One N.O., NPN
L5 = Two N.C., NPN
L6 = One N.O., NPN & two N.C., NPN

*See Page 129 for Limit Switch details.

NOTES:

1. For oversized motors, contact your local sales representative.
2. For extended temperature operation consult factory for model number.

Please provide a 3D CAD model of motor with all orders to ensure proper mounting compatibility.



For options or specials not listed above or for extended temperature operation, please contact Exlar